

Power Pulsar Foot & Back Massage Jets

The Most Innovative Foot & Back Massage Jet is Born!

Features:

- Natural Pulsations Without Any Moving Parts, Rejuvenate, Stimulate and Soothe Tired Feet & Back
- Low Profile “Spa Pulse Generator” Chamber/ Body Can be Mounted Under the Spa Footwell as Well as Spa Walls
- “Spa Pulse Generator” Creates and Dissolve Fine Bubbles into the Water to Enhance the Massage and Maximize Oxygenation of the Water
- Utilizing a Super High Output Venturi Fitting as Well as 12 Active Discharge Orifices, One Jet Replaces a Bank of Several Traditional Jets
- Radial Grooves Enhance the Massage Pattern and Prevent Restriction of Orifices Output

210-9840



Patent Pending

Part No.	Description	Case Qty.
210-9840	5" Power Pulsar Jet Assy 3/4" S Venturi SGMS	16
210-9830	5" Power Pulsar Jet Assy 3/4" S Venturi	16

Power Pulsar Foot & Back Massage Jets

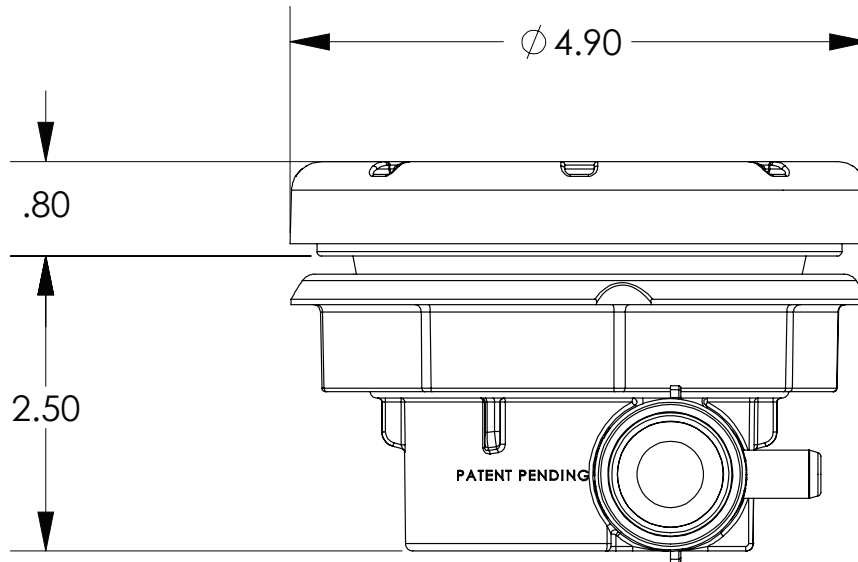

- Use a 3 15/16" Hole Saw and Make the Hole as Perpendicular as Possible to the Spa shell, Remove All Debris and Dust.
- Apply the Supplied EPDM Eil Gasket.
- Tighten the Nut to 24 Ft-Lbs Max.
- Glue the Supplied Venturi with PVC Primer and Glue, Avoid Excess Glue Spill into the Jet Body.

Description	PSI	GPM	Air Draw
5" Pulsar Jet; 3/4" Venturi Nozzle (with air)	5	21.4	68" WC
5" Pulsar Jet; 3/4" Venturi Nozzle (with air)	10	25.8	100" WC
5" Pulsar Jet; 3/4" Venturi Nozzle (with air)	15	30.1	140" WC
5" Pulsar Jet; 3/4" Venturi Nozzle (with air)	18	32.4	160" WC