

Pulsar Foot Massage Jets

The most innovative foot massage jet is born!

Features:

- Natural pulsations without any moving parts, rejuvenate, stimulate and soothe tired feet
- Low profile “Spa Pulse Generator” chamber/body can be mounted under the spa footwell
- “Spa Pulse Generator” creates and dissolve fine bubbles into the water to enhance the massage and maximize oxygenation of the water
- Utilizing a super high output Venturi fitting as well as 14 active discharge orifices, one jet replaces a bank of several traditional jets

210-9859-DSG
 1.5" Socket



1" Socket

Patent Pending

Part No.	Description	Case Qty.
210-9859-DSG	6" Pulsar Jet Assy 1.5" S Venturi	16
210-9869-DSG	6" Pulsar Jet Assy 1" S Venturi	16

Pulsar Foot Massage Jets

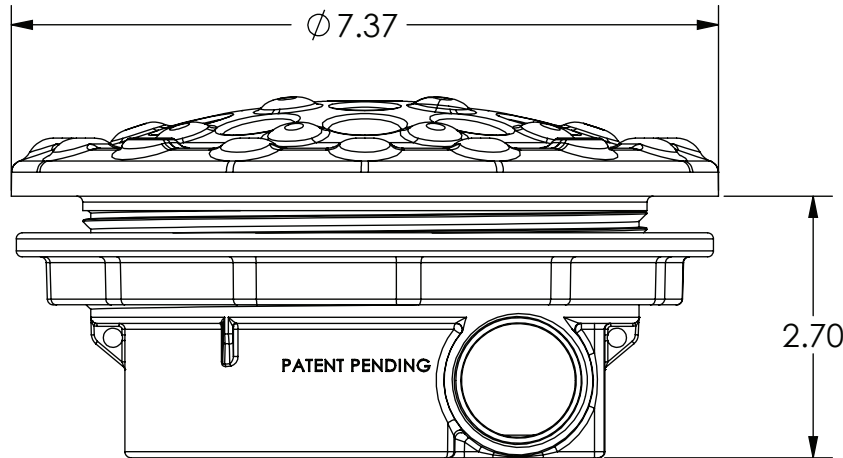

- Use a 6" hole saw and make the hole as perpendicular as possible to the spa shell, remove all debris and dust.
- Apply the supplied EPDM EII gasket.
- Tighten the nut to 40 Ft-Lbs Max.
- Glue the supplied venturi with PVC primer and glue, avoid excess glue spill into the jet body.

Description	PSI	GPM	Air Draw
6" Pulsar Jet; 1.5" Venturi Nozzle (with air)	5	38.5	72" WC
6" Pulsar Jet; 1.5" Venturi Nozzle (with air)	10	50.7	144" WC
6" Pulsar Jet; 1.5" Venturi Nozzle (with air)	15	60.8	200+" WC
6" Pulsar Jet; 1" Venturi Nozzle (with air)	5	37	84" WC
6" Pulsar Jet; 1" Venturi Nozzle (with air)	10	49.2	160" WC
6" Pulsar Jet; 1" Venturi Nozzle (with air)	15	59.7	200+" WC