

# 2 1/2" MINI STORM THREAD-IN GUNITE JET (229-1000 & 229-1010) INSTALLATION INSTRUCTIONS

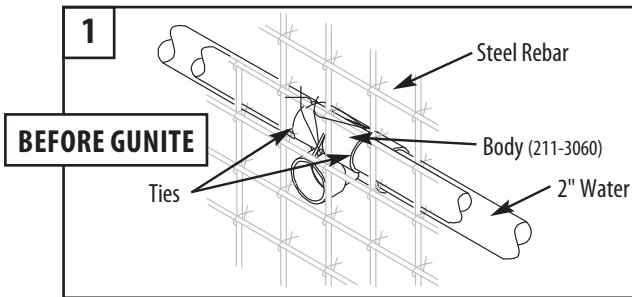

1. Hang Mini Storm Gunite Jet Body with ties through preset holes onto steel rebar.

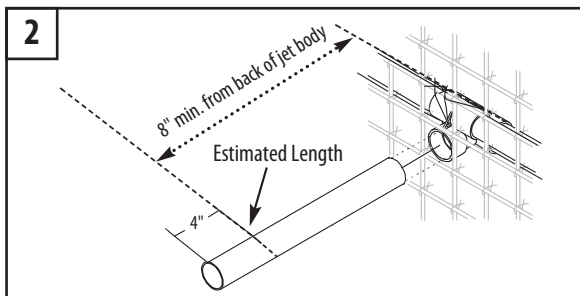

2. Estimate needed length of 2 1/2" PVC pipe by thickness of wall. Cut 2 1/2" PVC pipe at least 4" longer than estimated finish length. Then glue 2 1/2" PVC pipe to body.

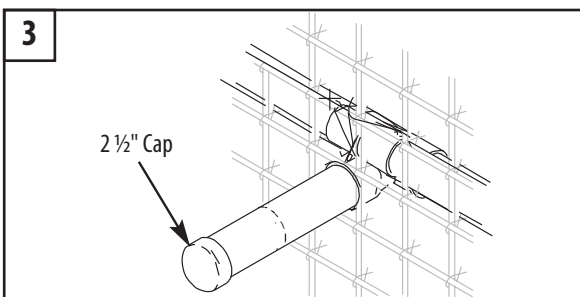

3. Glue 2 1/2" cap onto end of pipe for pressure test, before guniting.

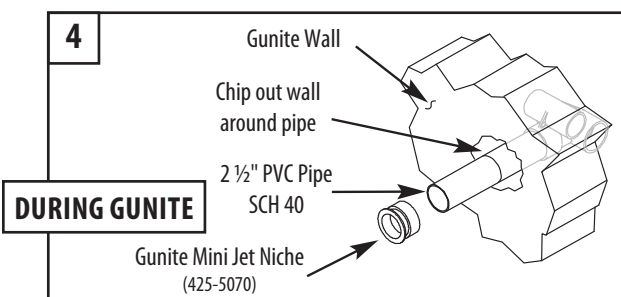

4. While guniting, scoop out gunite around the 2 1/2" PVC pipe, allowing room for the plaster niche (425-5070).

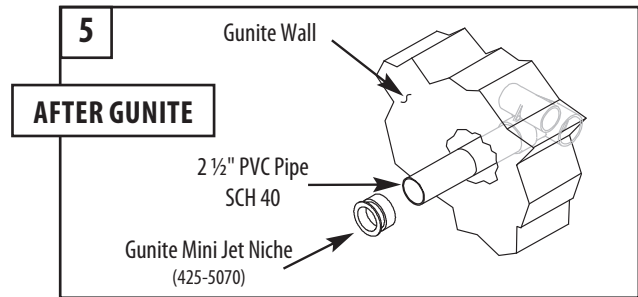

5. Before plastering, cut the 2 1/2" pipe so that the plastic niche will fit flush with the finished wall. Glue the plaster niche onto the pipe, then cover the niche with tape for plastering.

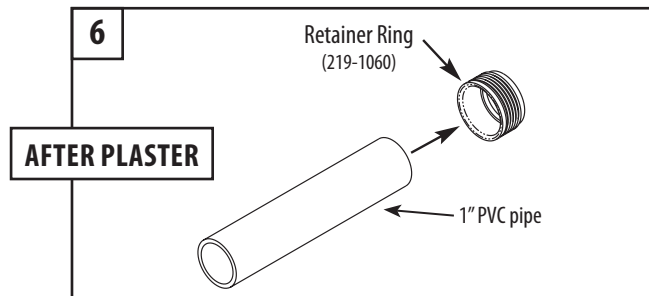

6. Cut a piece of 1" PVC pipe few inches longer than the 2 1/2" pipe and glue the threaded retainer ring to one end.

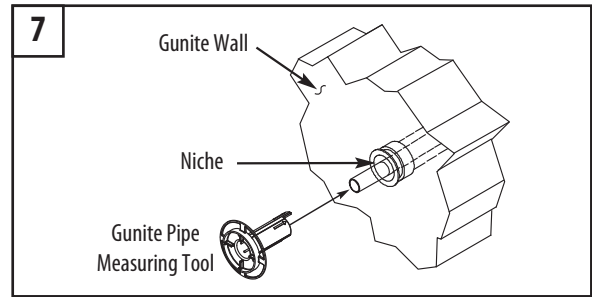

7. Insert 1" PVC pipe assembly through the niche and up to the jet body assembly and thread in. Slide the Gunite Pipe Measuring Tool (218-1960A) over the end of the pipe until flush against the plaster niche.

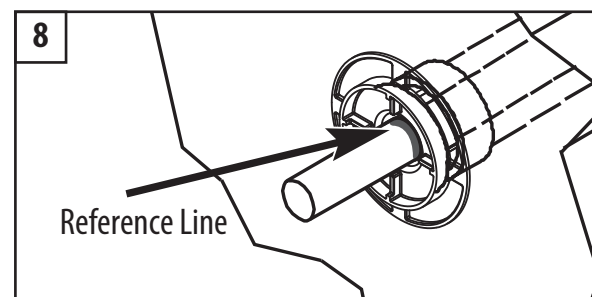

8. Draw a reference line on the 1" PVC pipe, flush with the back edge of the measuring tool.

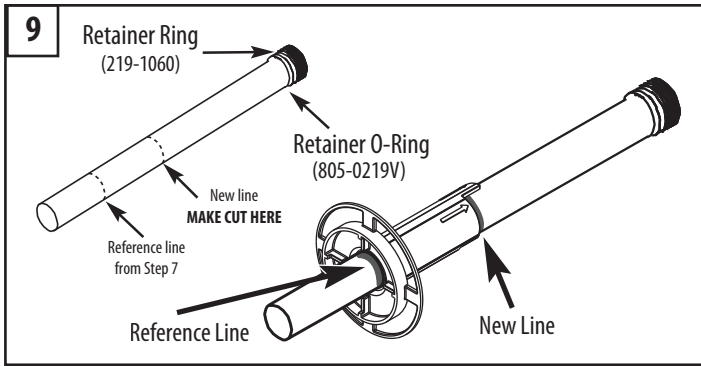

9. Remove the 1" pipe assembly from the jet body assembly and realign the measuring tool with the reference line. Make a new line at the Mini Storm Gunite Jet setback on the measuring tool.

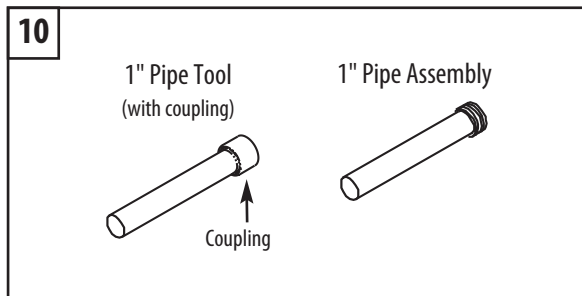

10. Create a 1" pipe tool with coupling attached to install the pipe assembly in the following steps.

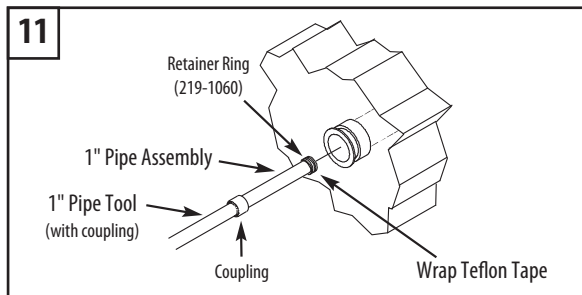

11. Install 4-6 wraps of Teflon tape around the threaded Retainer Ring, including 1 wrap over the O-Ring. Dry fit the pipe tool with coupling on the end of the 1" pipe assembly. Thread the assembly into the body assembly until it is snug and the pipe tool with coupling spins freely. Remove the pipe tool from the end of the pipe assembly.

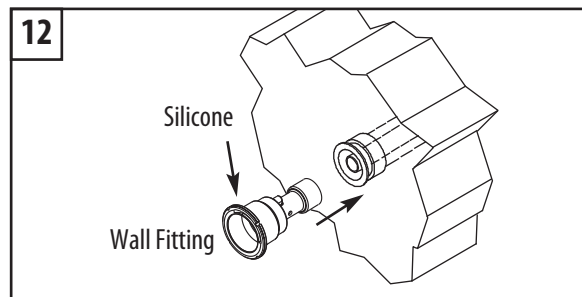

12. Put a bead of clear silicone sealant all around the back side of the wall fitting's flange. Prime and cement the end of the 1" pipe and fitting socket. Slide fitting onto end of 1" pipe until tight against the plaster niche.

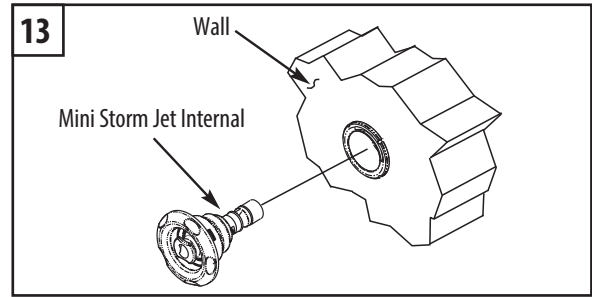

13. Insert Mini Storm Internal into the wall fitting and thread in passed first stop. Do not force. To reduce water flow, turn clockwise. To increase water flow, turn counter-clockwise until it stops turning. To remove, continue turning counter-clockwise past the stopping point. You will hear a snap to confirm release of Mimi Storm internal.

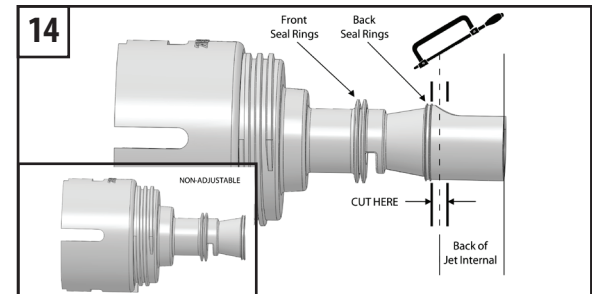

14. To make a non-adjustable jet internal, cut off the back of the jet internal after the back seal rings.



Always use at least one non-adjustable internal per spa to prevent deadheading pump.

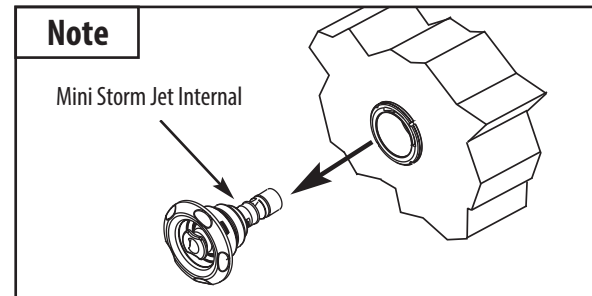

Note: To winterize the jet system, remove the jet internal from the wall fitting ONLY. Install a #10 rubber expansion plug inside of the fitting opening.

## MINI STORM THREAD-IN STRAIGHT BODY ASSEMBLY

1" Spigot Air x 1 1/2" Spigot Water

229-1010

Tee Body Assembly

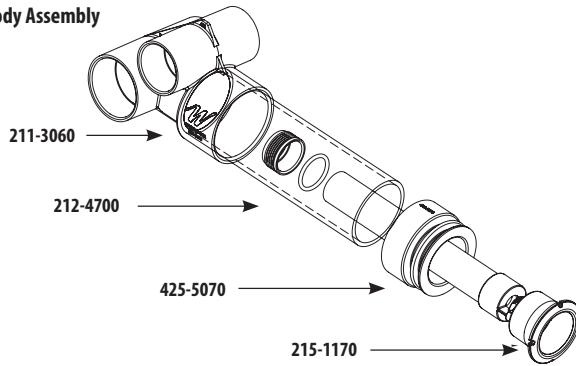

## MINI STORM THREAD-IN TEE BODY ASSEMBLY

1 1/2" S Air x 2" S Water

229-1000

Straight Body Assembly

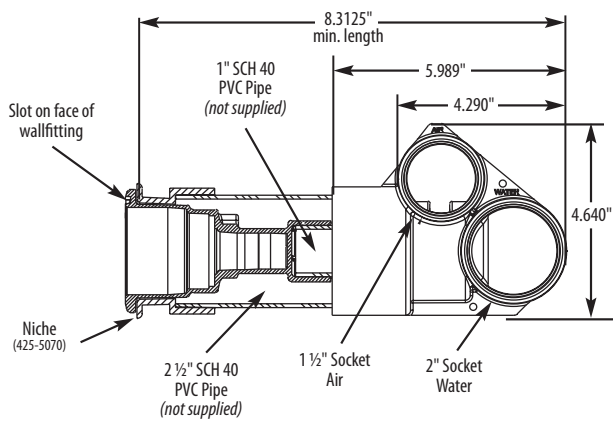
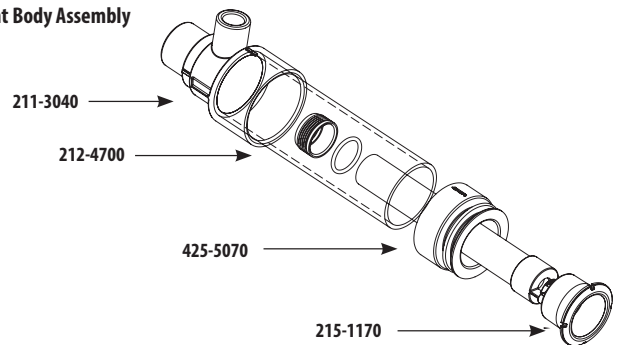

Always use at least one Non-Adjustable internal per spa to prevent deadheading pump.

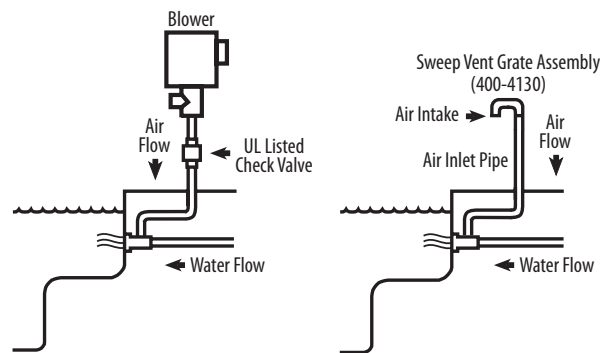

To prevent personal injury, shock, or property/equipment damage, an Air Spring Check Valve (2" 600-8160, 1 1/2" 600-8140) must be installed on the blower stand pipe in case of a water backup in the air line.

**NOTE:** If a blower is not being used, please direct the air intake toward the ground using the 2" Sweep Vent Grate Assembly (400-4130) on the Air Inlet Pipe.

## MINI STORM THREAD-IN JET INTERNALS AND ACCESSORIES

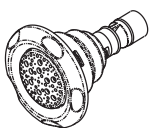

Galaxy  
229-0050 (White)  
10 GPM

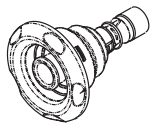

Directional  
229-7920 (White)  
10 GPM

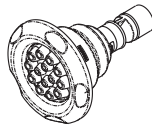

Multi Massage  
229-0070 (White)  
10 GPM

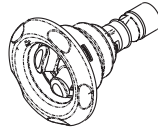

Twin Roto  
229-7950 (White)  
10 GPM

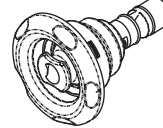

Roto  
229-0020(White)  
10 GPM

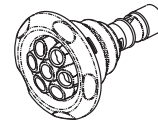

Massage (7 Nozzle)  
229-0030 (White)  
10 GPM

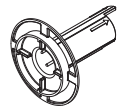

Wrench  
218-1960A

See Waterway Catalog for other versions.

## WARRANTY

For product registration visit: [www.waterwayplastics.com](http://www.waterwayplastics.com).  
For Warranty questions or claims please contact point of purchase.



2200 East Sturgis Road, Oxnard CA 93030 • Phone 805.981.0262 • Fax 805.981.9403

[www.waterwayplastics.com](http://www.waterwayplastics.com) • [waterway@waterwayplastics.com](mailto:waterway@waterwayplastics.com)