

IRON MIGHT PUMP INSTRUCTIONS

IMPORTANT SAFETY INSTRUCTIONS & WARNINGS • SAVE THESE INSTRUCTIONS • PLEASE READ AND FOLLOW ALL INSTRUCTIONS

ALL ELECTRICAL INSTALLATIONS SHOULD BE PERFORMED BY QUALIFIED ELECTRICIANS

- **WARNING:** Risk of electrical shock. Connect only to a Ground-Type Receptacle protected by a Ground-Fault Circuit Interrupter (GFCI). Potential risk of fire, electric shock or injury to person if misused. Do not install within an outer enclosure or beneath the skirt of the spa unless so marked.
- **WARNING:** To reduce the risk of injury, do not permit children to use this product unless they are closely supervised at all times.
- **CAUTION:** This pump is for use with permanently installed pools and may also be used with hot tubs and spas if so marked. **Do not use with storable pools.** A permanently installed pool is constructed in or on the ground or in a building such that it cannot be readily disassembled for storage. A storable pool is constructed so that it may be readily disassembled for storage and reassembled to its original integrity.

INSTALLATION INSTRUCTIONS

LOCATION: Place pump on level surface. Pump must be installed below water surface. Shut off valves should be installed on both the inlet and outlet of the pump for future maintenance. Installation area should be clear of any direct water and have adequate floor drainage. Pump should be protected from excessive moisture. Allow access area large enough to service both pump and plumbing.

The inlet and outlet have Waterway male union threads. Use Waterway tailpiece assemblies for best connection. These unions allow the pump to be removed for service without disturbing the plumbing.

HAND TIGHTEN UNIONS ONLY! DO NOT USE A WRENCH OR ANY ADHESIVES OR SOLVENTS!

DO NOT use pipe sealant. Use only Teflon tape or other sealing compounds approved for use with plastic. Some pipe sealants not approved for use with plastic will cause stress cracking of plastic parts. New installations often require plumbing inspections. This inspection is usually conducted using city water pressure. A pressure regulator should be used when performing this test and should not exceed 40 PSI during the pressure test. When the filter and pump are under pressure, insure that all air is removed from the system. Extreme care must be taken during the pressure test. **FAILURE TO FOLLOW THESE INSTRUCTIONS EXPLICITLY CAN RESULT IN PERSONAL INJURY AND WARRANTIES WILL BE VOIDED.**

MOTOR WIRING

1. Before working on any electrical connections be sure that the power is turned off.
2. All wiring must conform to local, state and/or national codes.
3. All wiring must conform to wiring diagram on the motor nameplate or on the back of the terminal cover.
4. Incoming line voltage must be within 10% of the nameplate voltage.
5. A solid copper bonding conductor no smaller than No. 8 AWG should be connected from the wire connector on the motor to all metal parts of the spa or hot tub structure, and, to all electrical equipment, metal conduit, and metal piping within five feet of the inside walls of a swimming pool, spa or hot tub when the motor is installed within five feet of the inside walls of the spa or hot tub.
6. **DO NOT** ground to a gas supply line.
7. Ground motor prior to connecting to electrical power.
8. Improper grounding can cause serious injury and damage to the motor, voiding the warranty.

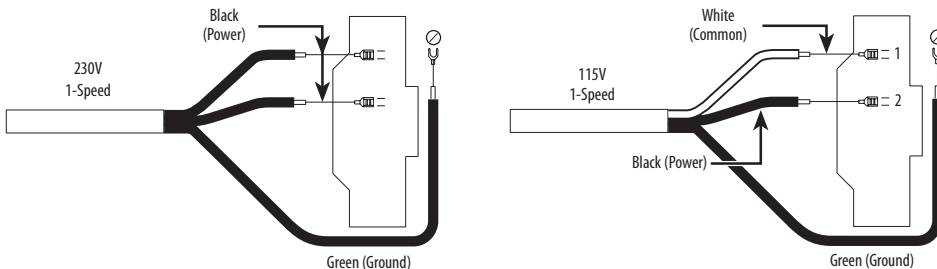

Ensure wiring circuit agrees with diagram and leads are securely tight.

WARRANTY

For product registration visit:
www.waterwayplastics.com.
For Warranty questions or claims please
contact point of purchase.



2200 East Sturgis Road, Oxnard CA 93030 • Phone 805.981.0262 • Fax 805.981.9403

TROUBLESHOOTING

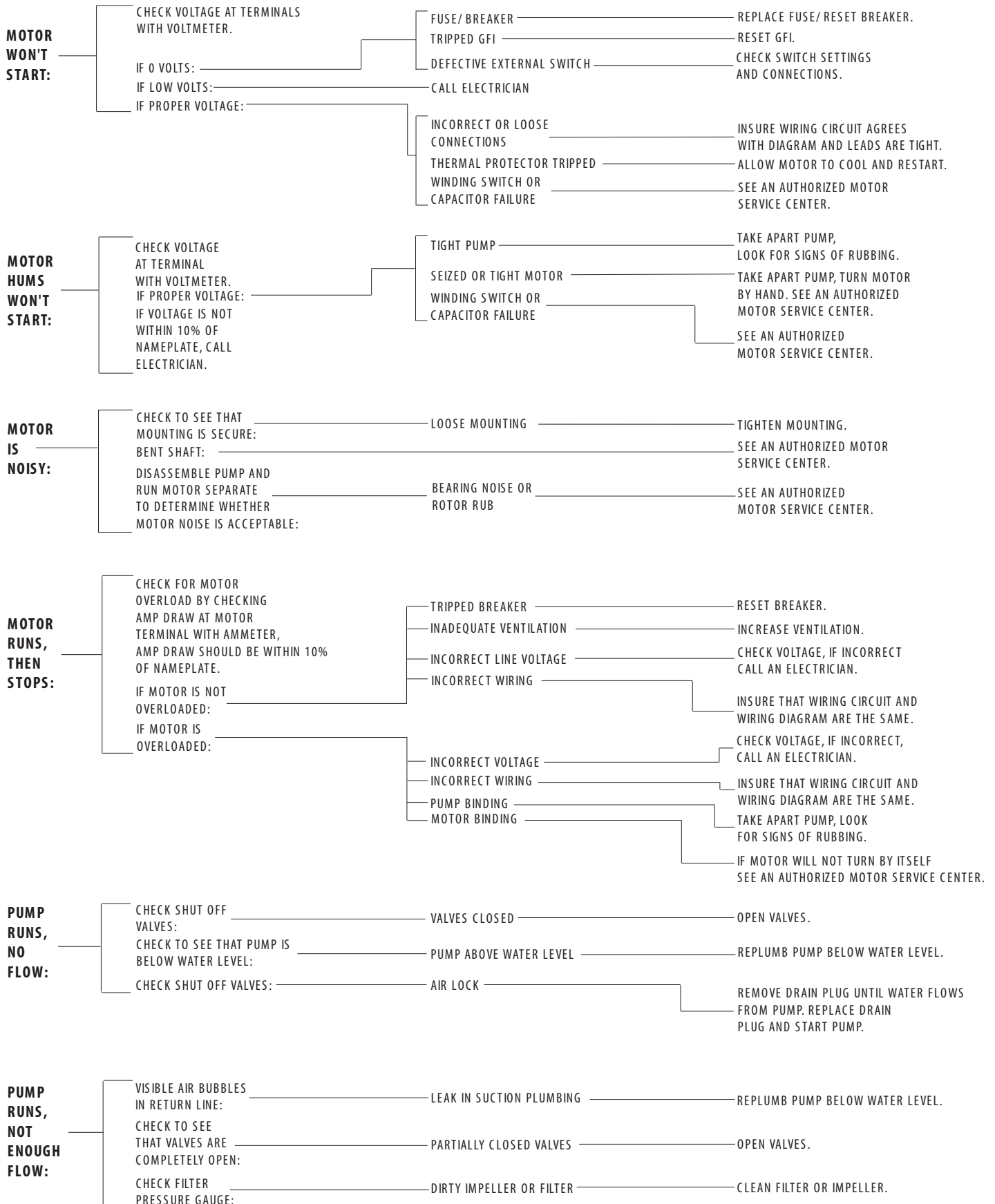

IRON MIGHT WET END

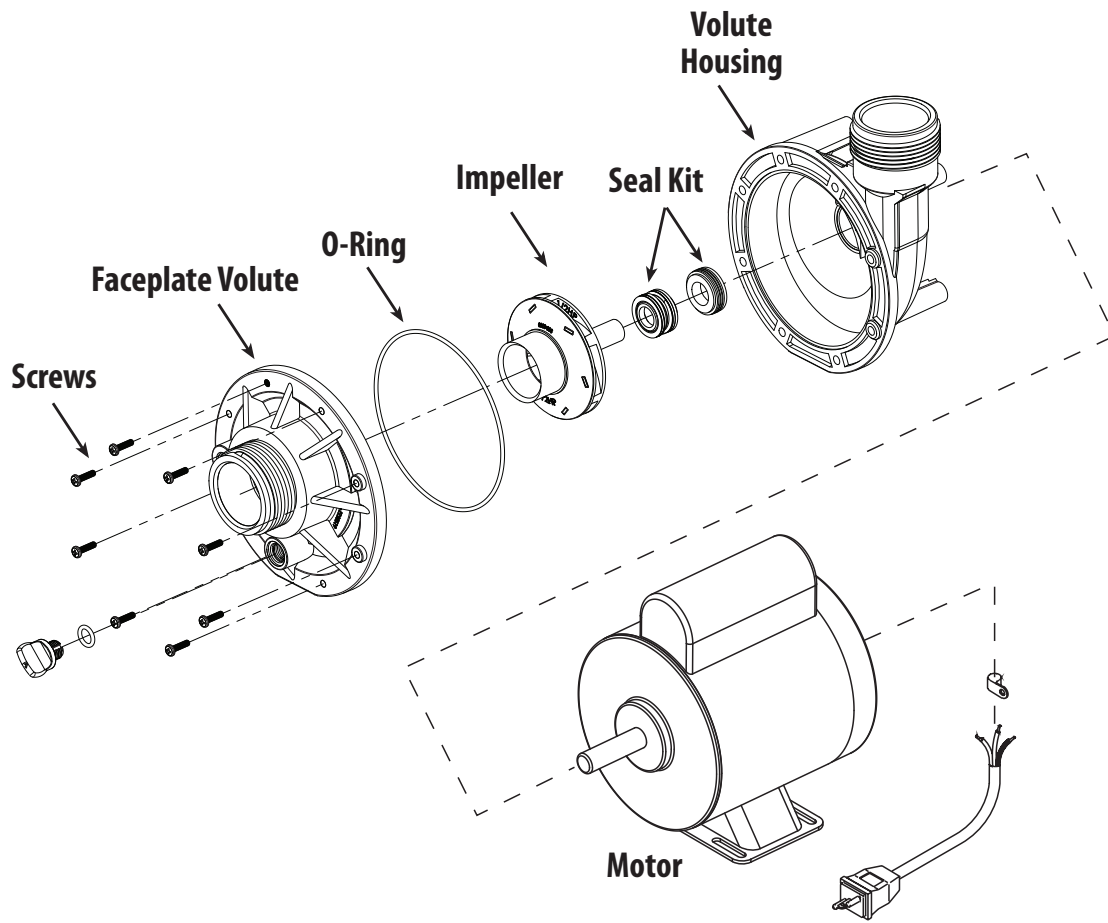

6" TRAP ASSEMBLY

