

PROCLEAN PLUS



CARTRIDGE FILTER

OWNER'S MANUAL

Installation • Operation • Parts

MODELS

PCCF-075

PCCF-100

PCCF-125

PCCF-150

PCCF-200



Scan QR Code for
Spanish and French



2200 East Sturgis Road, Oxnard CA 93030 • Phone 805.981.0262 • Fax 805.981.9403

www.waterwayplastics.com • waterway@waterwayplastics.com

TABLE OF CONTENTS

Safety Instructions	3
General Information.....	3
Installation.....	4
Initial Startup.....	4
Filter Assembly & Disassembly.....	5
Cartridge Cleaning Procedure.....	6
System Inspection & Winterizing.....	6
Troubleshooting Guide	7
Replacement Parts List.....	8

SPECIFICATIONS

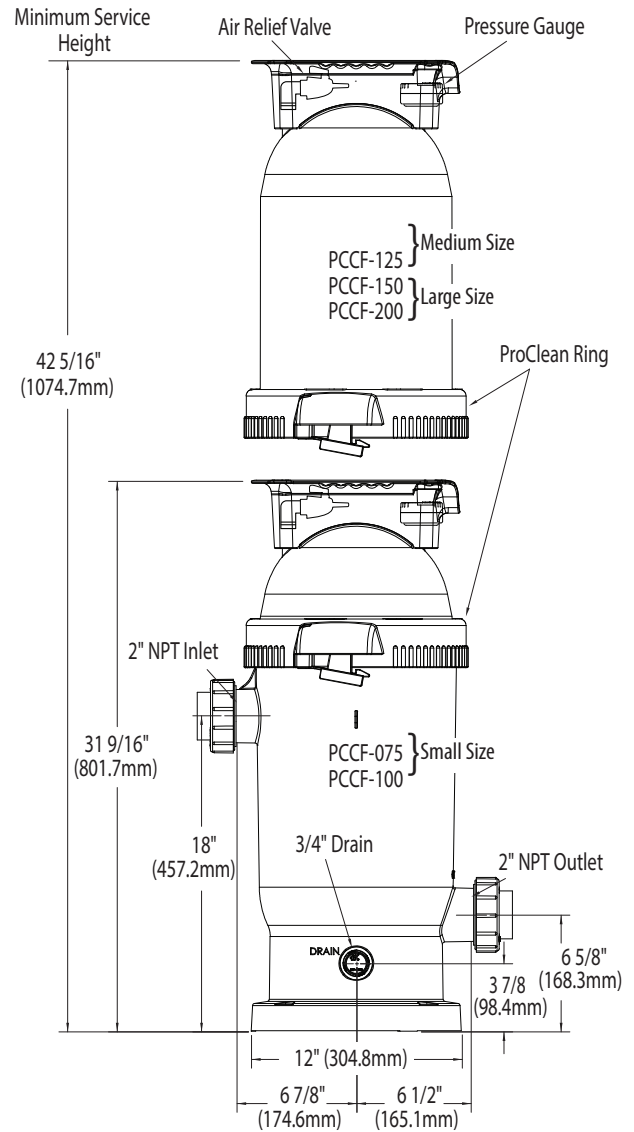
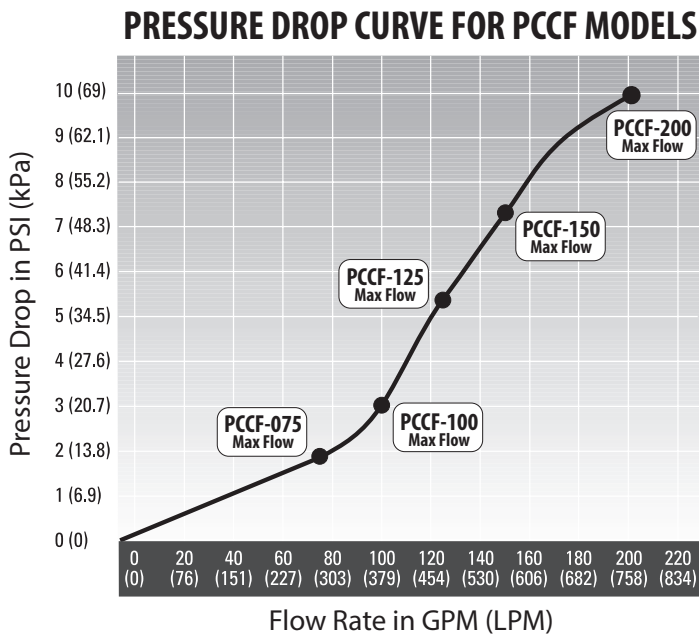



Figure 1 - Filter Dimensions in Inches (mm)

Table 1 - Filter Specifications

	Model No.				
	PCCF-075	PCCF-100	PCCF-125	PCCF-150	PCCF-200
Filter Area in Sq. Ft. (m ²)	75 (6.96)	100 (9.2)	125 (11.6)	150 (13.9)	200 (18.6)
Max. Residential Flow Rate GPM (LPM)	75 (284)	100 (379)	125 (473)	150 (568)	150 (568)
Max. Public Pool Flow Rate GPM (LPM)*	28 (106)	37 (148)	47 (177)	56 (212)	75 (284)
Max. Operating Pressure PSI (kPa)	50 (345)	50 (345)	50 (345)	50 (345)	50 (345)
Max. Continuous Water Temperature °F (°C)	104° (40°)	104° (40°)	104° (40°)	104° (40°)	104° (40°)

READ AND FOLLOW SAFETY INSTRUCTIONS

 This is the Safety Alert Symbol. When you see this symbol on your filter or in this manual, look for one of the following signal words and be alert to the potential for personal injury!

DANGER warns about the hazard that will cause death, serious injury or major property damage if ignored.

WARNING warns about hazards that can cause death, serious injury or major property damage if ignored.

CAUTION warns about hazards that can or will cause death, serious injury or major property damage if ignored.

NOTICE: indicates special instructions not related to hazards.

Carefully read and follow all safety instructions in this manual and on equipment. Keep safety labels in good condition; replace if missing or damaged.

WARNING **Hazardous Pressure. Incorrectly installed or tested equipment may explode, causing severe injury or property damage.** Read and follow instructions in Owner's Manual when installing and operating equipment. Have a trained pool professional perform all pressure tests.

 Do not connect filter to compressed air under any circumstances.

 Do not connect system to a city water system or other external source of pressurized water.

 Do not connect filter to pumps capable of exceeding 50 PSI (345 kPa) maximum pressure.

 Open air release valve to vent all air from system before operating the system.

WARNING Risk of falls and injury. Filter surface is slippery. Do not allow children to stand or play on filter.

GENERAL INFORMATION

WHEN TO CLEAN THE FILTER:

The filter cartridge should normally be cleaned when the pressure gauge reading increases 10 PSI over the start-up pressure.

In some pools, accessories such as fountains or pool cleaners may be noticeably affected by the normal decrease in flow as the filter becomes dirty. If so, clean the filter more frequently (that is, at a pressure increase of less than 10 PSI) in order to maintain the required flow.

Clean a new pool as well as possible before filling pool and operating filter.

A typical pool installation will require approximately one week to obtain and maintain the sparkle that your filter is capable of giving you.

Maximum pressure is 50 PSI (345 kPa). DO NOT connect the filter to a city water system or to an individual water well system.

The Waterway Cartridge Filter is designed to filter water for swimming pools and hot tubs only. On a new installation, we recommend:

1. Disassemble the filter after the initial cleanup. Follow "Filter Disassembly/Assembly Procedure" on page 5.
2. Remove and hose down the cartridge to remove contaminant.

Maintain pool water pH between 7.2 and 7.6.

Make sure that the Pro-Clean Ring is securely locked in place before operating filter.

Maintain the pressure gauge in good working order.

Replace a damaged gauge immediately.

Cleaning interval is based on pressure rise, not on the length of time the filter is operated. Different water conditions will have different normal cleaning intervals

NOTICE: Some pool disinfectants may clog the filter cartridge. To maximize cartridge life and filter cycle time, closely follow the disinfectant manufacturer's instructions when cleaning pool or filter. Failure to follow these instructions may affect warranty coverage of the cartridge.

INSTALLATION

FILTER MOUNT MUST:

- Provide weather and freezing protection.
- Provide space and lighting for easy access for routine maintenance.
- Provide ventilation and drainage for pump.
- Be on a reasonably level surface and provide adequate drainage.

PIPING:

NOTICE: Make sure that the filter and all piping can be drained for winterizing. See "Winterizing", page 6.

NOTICE: Overtightening can crack filter ports.

Use Teflon tape, Plasto-Joint Stik[®]† or Silastic RTV #732[®] on all threaded connections of plastic pipe and fittings.

DO NOT use pipe compounds on filter; it will cause the connection to crack. Do not use sealant on unions; assemble them dry and hand tight.

Support pipe independently to prevent strains on the filter.

Keep piping tight and free of leaks. Pump section line leaks may cause trapped air in filter tank or loss of prime at pump.

† Lake Chemical Co., Chicago, Ill.

ELECTRICAL:

Be sure that pump grounding meets local and National Electrical Code Standards. All wiring and grounding of associated equipment must meet local and National Code Standards.

INITIAL START-UP

⚠ Be sure pump is OFF before starting procedure. Do not operate filter at more than 50 PSI (345 kPa).

1. Securely lock the Pro-Clean Ring in place by rotating it **CLOCKWISE** until it "clicks" past the safety latch (see Figure 3). Stop turning as soon as the ring clicks past the latch. The ring may feel slightly loose, but it will tighten up when the pump is on and the filter is under pressure.
2. Fill the trap on the pump with water.
3. Open the air release valve on top of the filter.
4. Open valves separating the filter from the rest of the system.

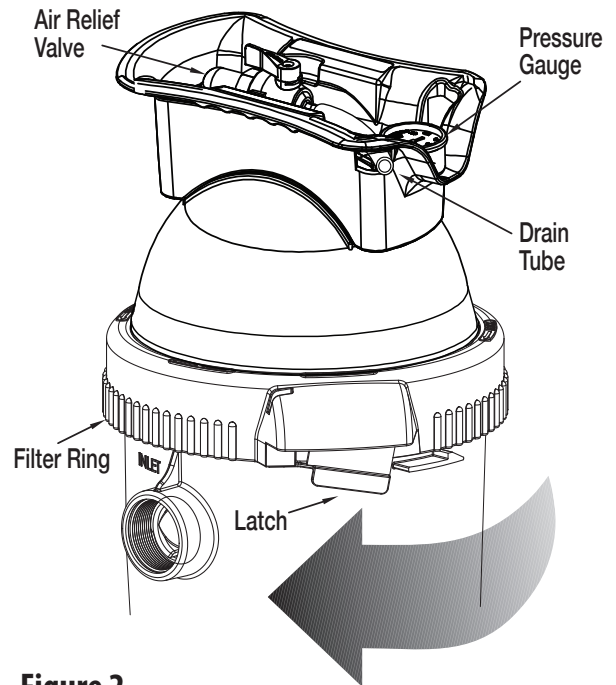

Figure 2

5. Start the pump to purge air from the system and stay clear at least 10 feet from the filter.
6. When a steady stream of water comes from the air release valve, close the valve.

NOTICE: Leaking around the filter ring may indicate that the ring is not fully locked. In this case proceed as follows:

- A. Stop the pump and open the air release valve then release any pressure within the filter.
- B. Remove the drain plug and drain all water from the filter.
- C. Rotate the filter ring clockwise until it locks behind the safety latch (see Figure 3).
- D. If the ring was already locked, remove it and the filter lid assembly. Inspect and clean the O-ring and all sealing surfaces. Re-lubricate the O-ring, if necessary.

NOTICE: Lubricate the O-ring sealing area inside the upper tank lip with silicone grease, as other lubricants may cause the O-ring to swell. **DO NOT** lubricate the filter ring or the threads on the tank shell as this may collect grit and make removal difficult.

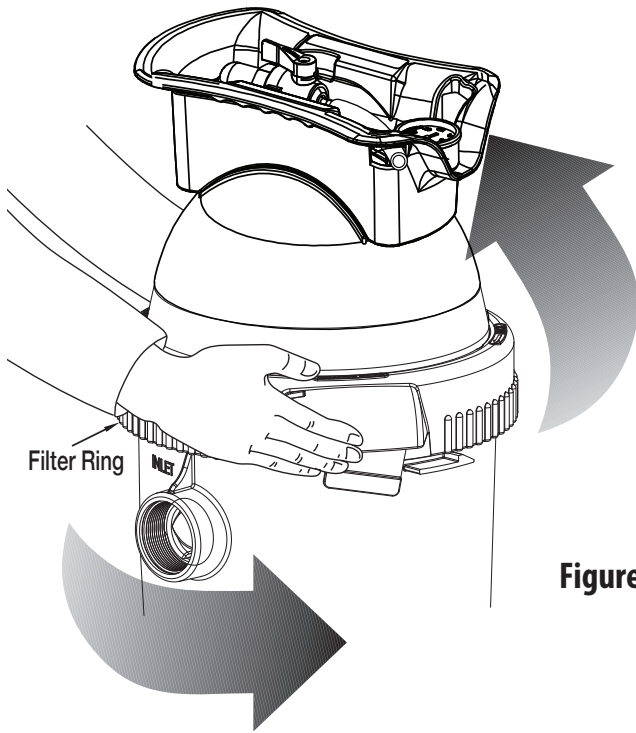

Figure 3

FILTER DISASSEMBLY / ASSEMBLY PROCEDURE

BEFORE DISASSEMBLING FILTER:

- 1. STOP PUMP.**
- 2. OPEN air release valve and drain fitting.**
- 3. WAIT until all pressure is released and water drained from filter tank and system before loosening filter ring.**

DISASSEMBLY:

1. Stop the pump.
2. Open air release valve on top of filter tank to release all pressure from inside of tank.
3. Remove the drain cap and drain all water from the tank.
4. Remove filter lid assembly as follows:
 - A. Press the safety latch (below the ring) toward the tank to release it (see Figure 3).
 - B. Hold the latch in the release position and rotate the ring COUNTERCLOCKWISE to remove it. If the ring is difficult to turn, tap it gently with a rubber mallet to overcome initial resistance.
5. Inspect the O-ring for cuts, cracking, deformation or signs of wear; replace if necessary.

NOTICE: Do not remove the O-ring unless you need to replace it. To remove it, hook it out of its groove with a stiff curved piece of wire inserted through the small access slot in the bottom of the tank lid assembly.

ASSEMBLY:

1. Inspect and clean the tank, ring threads and O-ring groove. Replace damaged parts as necessary.
2. Install the filter cartridge in the tank. Push down firmly to seal it.
NOTICE: Lubricate the O-ring sealing area inside the upper tank lip with silicone base grease, as other lubricants may cause the ring to swell. **DO NOT** lubricate the filter ring or the threads on the tank shell as this may collect grit and make removal difficult.
3. Install the O-ring in the tank lid assembly O-ring groove. Be sure that the O-ring is clean and not twisted.
NOTICE: Do not remove the O-ring unless you need to replace it.
4. Place the filter ring squarely over the tank shell threads and rotate it **CLOCKWISE** until it is securely latched.
5. Follow instructions in the "Initial Startup" section of this manual.

SAFETY LATCH

The purpose of the safety latch is to hold the filter ring in the locked position. If the latch is damaged, replace it as follows:

1. Press up on the small catch on the bottom of the safety latch and press or tap the latch out of the slot in the tank.
2. Slide the new latch into position until it latches in place.

NOTICE: **DO NOT** operate the filter if the safety latch is damaged or will not hold the filter ring in the locked position.

CARTRIDGE CLEANING PROCEDURE

WHEN TO CLEAN THE FILTER:

The filter cartridge should normally be removed and cleaned when the pressure gauge reading increases 10 PSI over the start-up pressure. Follow all steps in the “Disassembly” section of this manual (page 5).

NOTICE: When sanitizing your pool using PHMB (polyhexamethylene biguanide) based cleaners, use ONLY PHMB cleaners to clean the cartridge. When using PHMB sanitizers, the filter cartridge MUST be cleaned more thoroughly and frequently than for a pool using chlorine. Follow manufacturer’s instructions carefully. Use of any other type of cleaners with PHMB pool sanitizers will void the filter’s warranty.

1. Remove the drain cap and flush all foreign material from the inside of the tank before removing the filter cartridge.
2. Allow the tank to drain.
3. Lift out the cartridge and hose it down thoroughly. Spray the entire cartridge surface. Allow cartridge to drain.
4. Inspect the cartridge. If necessary, repeat the washing operation. If the cartridge is damaged, replace it.
5. Follow the steps in the “Assembly” (page 5) and “Initial Start-Up” (page 4) sections of this manual.

NOTICE: When this procedure no longer adequately cleans the cartridge, discard the cartridge and replace it with a new one.

SYSTEM INSPECTION

GENERAL:

NOTICE: DO NOT use solvents to clean the filter. Solvents may damage plastic components in the system.

NOTICE: Open the air release valve and bleed all air from the filter each time the filter is drained or disassembled.

WEEKLY INSPECTION:

1. Remove debris from the pool skimmer basket.
2. Stop the pump; open the air release valve to release all pressure.
3. Remove the pump trap cover and basket; remove debris.
4. Check the pump for leaks. If found, see pump owner’s manual.
5. Replace the trap basket and the cover. Tighten the cover securely hand tight. DO NOT use a lid wrench to tighten it.
6. Start the pump. When the filter air release valve runs a solid stream of water, close the valve.
7. When the system has returned to normal operation, check the filter pressure. If the filter pressure is 10 PSI (69 kPa) or more higher than the initial start-up pressure, the filter needs cleaning. See “Cartridge Cleaning Procedure” at left.

WINTERIZING

NOTICE: Protect the filter from freezing. Allowing the filter to freeze will damage it and will void the warranty. If possible, take the system indoors for storage.

1. Clean the filter according to instructions (left) before winterizing.
2. Stop the pump.
3. Open the air release valve; open any system valves.
4. Remove the drain plugs from the trap, pump and filter.
5. Gravity drain system and filter as far as possible.
6. Disassemble the filter (follow instructions under “Filter Disassembly”, page 5). Remove the filter cartridge and store it in a warm, dry area.
7. Cover the filter with plastic or tarpaulin to prevent water entrance and freezing.

TROUBLESHOOTING GUIDE

1. Short Cycle Time:

NOTICE: Cycle time will vary with each location and between different areas of the country. The following causes and remedies are for cycle times shorter than normal for your area.

- A. Chlorine residual too low; maintain proper residual (consult pool professional for recommendation).
- B. Filter cartridge is dirty or plugged; thoroughly clean the filter (see no. 4, "Plugged Cartridge", and "Cleaning Cartridge Procedure", page 6).
- C. Water is chemically out of balance; consult pool professional.
- D. Algae in the pool; apply heavy dose of chlorine or algaecide as recommended by the pool manufacturer.
- E. Replace the cartridge.

2. Low Flow/High Pressure:

- A. Cartridge plugged; clean filter thoroughly (see page 6).
- B. Pipe blocked downstream from filter; remove obstruction.
- C. Piping too small; use larger pipe (consult dealer for sizing).

3. Low Flow/Low Pressure:

- A. Plugged pump or plugged debris basket; clean thoroughly.

4. Plugged Cartridge:

- A. Insufficient cleaning; follow cleaning instructions closely and clean thoroughly (see page 6).
- B. Water chemically out of balance; consult pool professional.
- C. Excessive air in filter; vent air from tank and check for pump suction pipe leaks. Clean air bleed tube in cartridge assembly.

- D. Pool water contains iron; consult your pool professional.
- E. Heavy or improper application of powdered chlorine tablets using a binder; consult your pool professional.
- F. Algae in the pool; apply heavy dose of chlorine or algaecide as recommended by the pool manufacturer.
- G. Use of incorrect chemicals with PHMB sanitizers; replace filter cartridge.
- H. Replace the cartridge.

5. Pool Water Not Clean:

- A. Chlorine residual too low; maintain adequate chlorine residual (consult pool service technician for recommendation).
- B. Filter cartridge torn, plugged or punctured; replace cartridge.
- C. Pool water contains iron; consult your pool professional.
- D. Heavy or improper application of powdered chlorine tablets using a binder; consult your pool professional.
- E. Algae in the pool; apply heavy dose of chlorine or algaecide as recommended by the pool manufacturer.
- F. Replace the cartridge.

6. Pool Cleaner Stops Working:

- A. Clean filter and observe performance of pool cleaner.
- B. If pool cleaner performs better after filter has been cleaned, use a shorter cleaning cycle for the filter (that is, clean the filter after a pressure rise of less than 10 PSI).

PROCLEAN PLUS REPLACEMENT PARTS

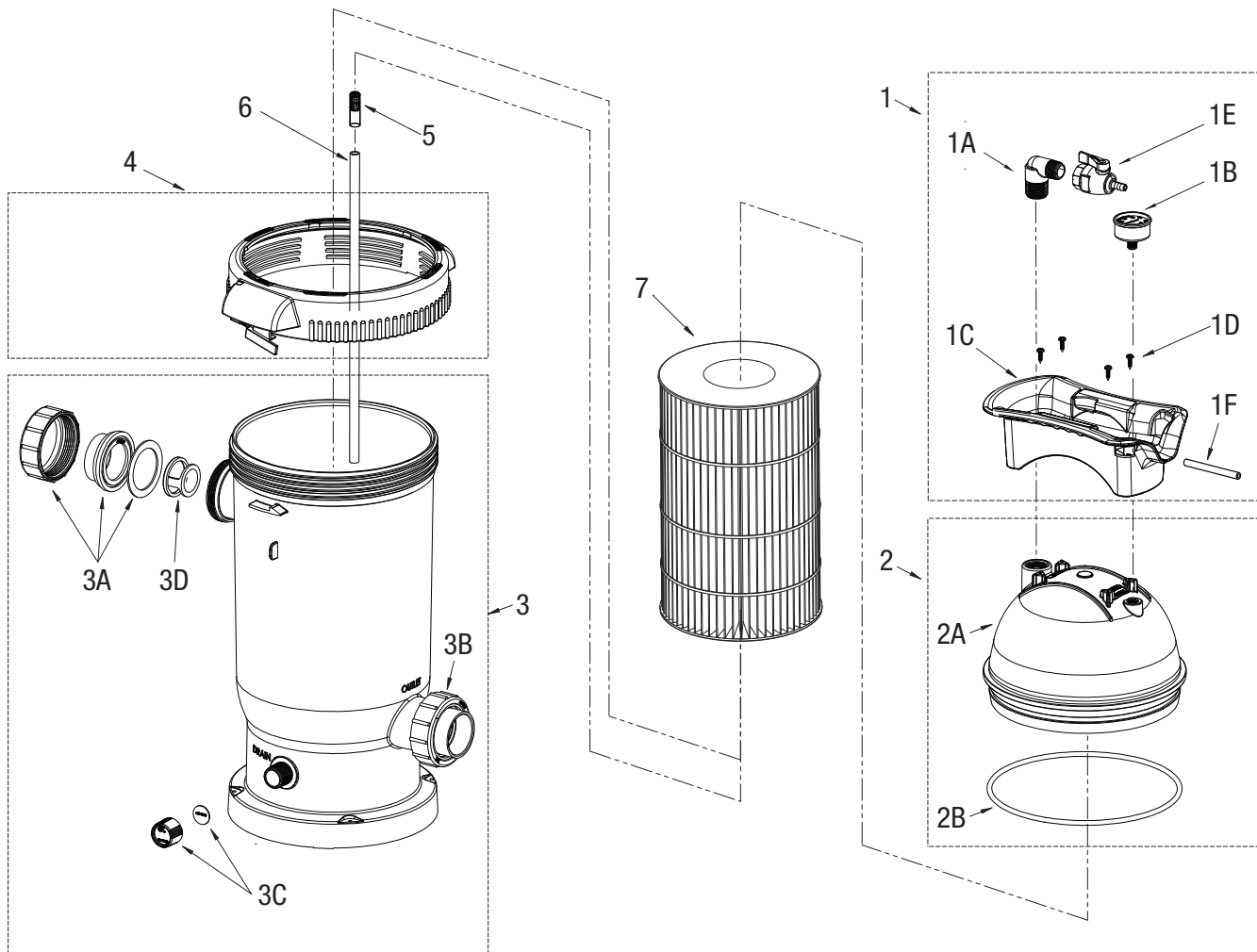

PROCLEAN PLUS CARTRIDGE FILTER REPLACEMENT PARTS

Item	Part No.	Description
1	550-0611	Filter Lid & Handle Assembly – 75 - 100 sq. ft. (includes #1A - 1F)
	550-0621	Filter Lid & Handle Assembly – 125 - 150 sq. ft. (includes #1A - 1F)
	550-0631	Filter Lid & Handle Assembly – 125 - 200 sq. ft. (includes #1A - 1F)
1A	600-0220	Air Relief Valve Elbow
1B	830-4000SS	Pressure Gauge
1C	519-7631	Handle
1D	819-9002	Screws
1E	805-0448	Air Relief Valve
1F	110-0120-6	Drain Tube
2A	519-0201	Small Filter Lid
2B	805-0448	O-ring
3	515-0201	Filter Body (includes #3A-3D)
3A + 3B	400-5961-2B	2.5" Union w/2" STP w/Gasket (2)

Item	Part No.	Description
3C	550-0260	Drain Cap w/ Gasket Assy
3D	417-6351	Adaptor 2" FPT w/2.5" Union Threads (2)
4	550-0701	Lock Ring Assembly
5	500-7310	Screen/Sock w/ Clamp Assy
6	872-4000E	Air Bleed Tube - 75 / 100 sq. ft.
	872-4000L	Air Bleed Tube - 125 / 150 sq. ft.
	872-4000F	Air Bleed Tube - 200 sq. ft.
7	817-0075P	Filter Cartridge - 75 sq. ft.
	817-0100P	Filter Cartridge - 100 sq. ft.
	817-0125P	Filter Cartridge - 125 sq. ft.
	817-0150P	Filter Cartridge - 150 sq. ft.
	817-0200P	Filter Cartridge - 200 sq. ft.

LIMITED WARRANTY

Waterway Plastics manufactures its products and equipment in accordance with very high standards of workmanship. We use the best materials available and maintain the highest quality procedures practical in the industry. For Warranty, product must be registered at time of purchase/installation at www.waterwayplastics.com. For Warranty claims or questions, please contact point of purchase.