

# ClearWater™

## HIGH RATE SAND FILTER



**STANDARD SYSTEM WITH ONE-PIECE BASE  
OWNER'S MANUAL**

# CLEARWATER STANDARD SAND FILTER SYSTEM OWNER'S MANUAL



**WARNING: A GFCI is required. Follow national and local building and safety codes.**

Your ClearWater Standard Sand Filter System is shipped complete from Waterway, with all needed components ready for assembly and installation.

System will require a 110 Volt / 20 Amp service. **DO NOT** use extension cords. Use will void warranty on pump motor. The pool equipment should be located between the pool skimmer and return line. The filtration system should not be installed less than 2 ft. and no more than 5ft. from the pool. The ClearWater Standard Sand Filter System needs to be on a completely flat level / surface (patio block, cement slab, etc.). Assemble filter system only after above ground pool

is installed. Fill pool with water. **IMPORTANT:** Do no raise water level above pool return line or skimmer throat until installation is complete.

Open shipping carton in an upright position checking contents, as follows:

- |                            |                        |
|----------------------------|------------------------|
| 1. One-piece mounting base | 5. One fittings bag    |
| 2. One pump                | 6. One collar wrench   |
| 3. One filter              | 7. Trap assemblies     |
| 4. Two corrugated hoses    | 8. Pump to filter hose |

## INSTALLATION INSTRUCTIONS



**WARNING! READ ALL INSTRUCTIONS AND WARNING LABELS BEFORE OPERATING FILTER!**

1. Open box and remove all contents.
2. Place the base on a level, secure surface - in the final assembly location.
3. There is no need to disassemble any of the parts from the box. Position the sand filter body onto the base. The drain should be aligned with the recess in the base during this operation. Fill the body with water to keep it from moving during installation of other parts.
4. Open the pump and trap boxes. Remove the lid from the trap assembly and get the union nut package out. Put the trap lid back on. Install the union nut onto the flange inlet opening of the trap using the two screws from the bag. Install the trap onto the inlet of the pump (see detail 2).
5. Position the pump assembly on the base and align the holes in the base with the slots on the motor base. Insert the anchor housings through the motor slots and base (see detail 1). Insert the anchor pins through the center of the anchor housings to secure the pump to the base.
6. Add sand. Make sure the assembly on the base is positioned where you want it to be. With sand fill guide positioned in filter tank opening, add only recommended grade silica sand. (See Fill Chart.) Remove sand fill guide. **IMPORTANT:** Clean and remove all debris from filter tank flange after adding sand.
7. Get the multi-port valve. Visually check and make sure the O-Ring is installed on the bottom. Make sure that the sealing surface on the body is free from any sand or other debris. Install the multi-port valve onto the body with the inlet and outlet ports facing the pool. The standpipe that is already installed in the body should

fit directly in the center of the multi-port valve stem. Seat the valve as evenly as possible by hand.

8. Lift the threaded collar of the body and thread the nut (on the multi-port valve) onto it. The easiest way to do this is to use both hands and lift the collar with your finger tips under both sides and use your thumbs to start turning the nut in a clockwise direction. Once it is started, you need to tighten the nut (using the molded on handles) until the valve is securely on the body (see detail 3).
9. Position and hand tighten sand filter hose assembly (#29) to top inlet port. Position gasket (#21, 711-4010) and hand tighten onto pump. **DO NOT** over tighten (Detail 6).
10. Hand tighten 1 1/2" Buttress x 1 1/2" MPT (#31, 417-4161) to bottom outlet port. **DO NOT** over tighten.
11. Position O-Ring (#2, 805-0224) onto 1 1/2" MPT x 1 1/2" hose male smooth adapter, (#26, 417-6141). Hand-tighten onto suction side of pump trap (Detail 7).
12. Apply Teflon tape (4 wraps ideal) to pressure gauge (#3, 830-2000). Thread into multi-port valve.
13. Remove 4 hose clamps (#27, 872-0010) and position over end of corrugated hoses, (#28, 872-9002). Install corrugated hose between the 1 1/2" Buttress x 1 1/2" MPT (#31, 417-4161) on multi-port valve and to pool return fitting. Tighten hose clamps. Install the other corrugated hose between the 1 1/2" MPT x 1 1/2" hose male smooth adapter (#26, 417-6141) and to pool skimmer fitting. Tighten hose clamps. **NOTE:** Soften hose ends with warm water to ease installation onto fittings (if necessary).
14. Install waste adapter fitting (#1, 425-1928) with O-Ring (#2, 805-0224) (Detail 5).

## SYSTEM START UP

1. Fill pool until water is halfway up length of skimmer throat.
2. Make sure pump trap is full of water. Slightly loosen trap lid to relieve pressure and allow water to fill trap. Re-tighten lid.
3. Make sure multi-port valve handle is in **Filter** position.
4. Plug pump into GFCI outlet and turn pump on. Turn two-speed pumps to high.
5. Make note of start-up pressure on gauge.
6. Checks for leaks.

## WINTERIZATION

1. Backwash filter system completely. See Cleaning Instructions.
2. Run a filter cleaning chemical through filter system as per cleaner instructions.
3. Turn pump off. Disconnect hoses from skimmer and return fitting.
4. Remove drain plug cap from bottom of filter tank. **DO NOT** remove hex drain assembly (#14). To remove Item self-threading drain screen (#14), remove drain cap (#15) and use as tool to remove.
5. Unscrew drain plugs located at bottom of pump trap and front of pump housing. Let water drain completely.
6. Disconnect filter to pump connection. Loosen union connection on discharge of pump and remove from pump. **DO NOT** lose 2" union gasket. Lift and remove pump and pump base from filter base. Store inside.

## CLEANING INSTRUCTIONS

**NOTE:** When pressure gauge reading is 5 PSI or higher than original starting pressure, the filter needs to be cleaned. The ClearWater Standard Sand Filter System features our exclusive 7-Position Multi-Port Valve, which ensures safe and simple filter maintenance.

Pressurized vessel. Never attempt to loosen or open collar assembly (#6 & 7) while system is running. It could cause severe injury or harm to user. **NEVER CHANGE VALVE POSITION WITH**



**PUMP RUNNING!**

1. Turn off pump.
2. Attach backwash hose (optional) to waste port adapter.
3. Rotate multi-port valve handle to **Backwash** position. Turn pump on and run for 90 second intervals or until discharge water is clear. Turn pump off.
4. Rotate multi-port valve handle to **Rinse** position. Turn pump on for 30 seconds.
5. Repeat steps 3 & 4 until all discharge water is clear while pump is turned on.
6. Rotate multi-port valve handle to **Filter** position. Turn pump on. Valve is now in normal operating position.

# CLEARWATER STANDARD SAND FILTER SYSTEM PARTS LIST

Item	Part No.	Description
1	425-1928	Waste Adapter Fitting
2	805-0224	O-Ring
3	830-3000	0-30 PSI Gauge
4	WVS003-A	Multi-Port Valve Assembly
5	718-1860	Nut
6	505-2300	Retainer
7	505-3030	Threaded Sleeve
8		
9	805-0435	O-Ring
10	502-2011	Sand Fill Guide
11	505-3000	Threaded Sleeve for Split Nut
12	505-2040	16" Lateral & Manifold Assembly
	505-2050	19" Lateral & Manifold Assembly
	505-2060	22" Lateral & Manifold Assembly
	505-2080	26" Lateral & Manifold Assembly
13	515-1607	16" Sand Filter Body
	515-1907	19" Sand Filter Body
	515-2007	22" Sand Filter Body
	515-2067	26" Sand Filter Body
14	602-5311	Self-Threading Drain Screen
15	602-5321	Drain Cap
16	672-7241	One-Piece Base
17	820-0017	Flat Washer - 3/8"
18	819-0016	3/8" Bolt - 22" / 26" Sand Filter
	819-0019	3/8" Bolt - 19" Sand Filter
	819-0020	3/8" Bolt - 16" Sand Filter
19	PH1100	1 HP - 1-Speed - Hi-Flo II Pump
	PH1150	1 1/2 HP - 1-Speed - Hi-Flo II Pump
	PH1200	2 HP - 1-Speed - Hi-Flo II Pump
	PH2100	1 HP - 2-Speed - Hi-Flo II Pump
	PH2150	1 1/2 HP - 2-Speed - Hi-Flo II Pump
	PH2200	2 HP - 2-Speed - Hi-Flo II Pump
20	429-7300	Pin & Anchor Assembly
21	711-4010	2" Gasket
22	319-3230	6" Basket Assembly (not shown)
23	319-2170	6" Pump Trap
24	805-0436	O-Ring,
25	319-4100	2-Piece 6" Pump Trap Lid Assembly
26	417-6141	1 1/2" MPT x 1 1/2" Hose Male Smooth Adapter
27	872-0010	Hose Clamp - Stainless Steel
28	872-9002	Corrugated Hose - Black
29	550-1801	16" Sand Filter Hose Assembly
	550-1811	19" Sand Filter Hose Assembly
	550-1821	22" Sand Filter Hose Assembly
	550-1831	26" Sand Filter Hose Assembly
30	711-4000	1 1/2" Gasket
31	417-4161	1 1/2" Buttress x 1 1/2" MPT
32	550-1841	Return Sweep Assembly
	810-0082-1	Instruction Sheet

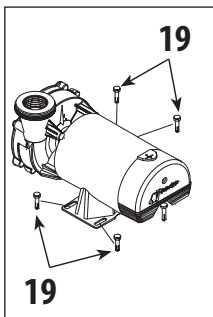
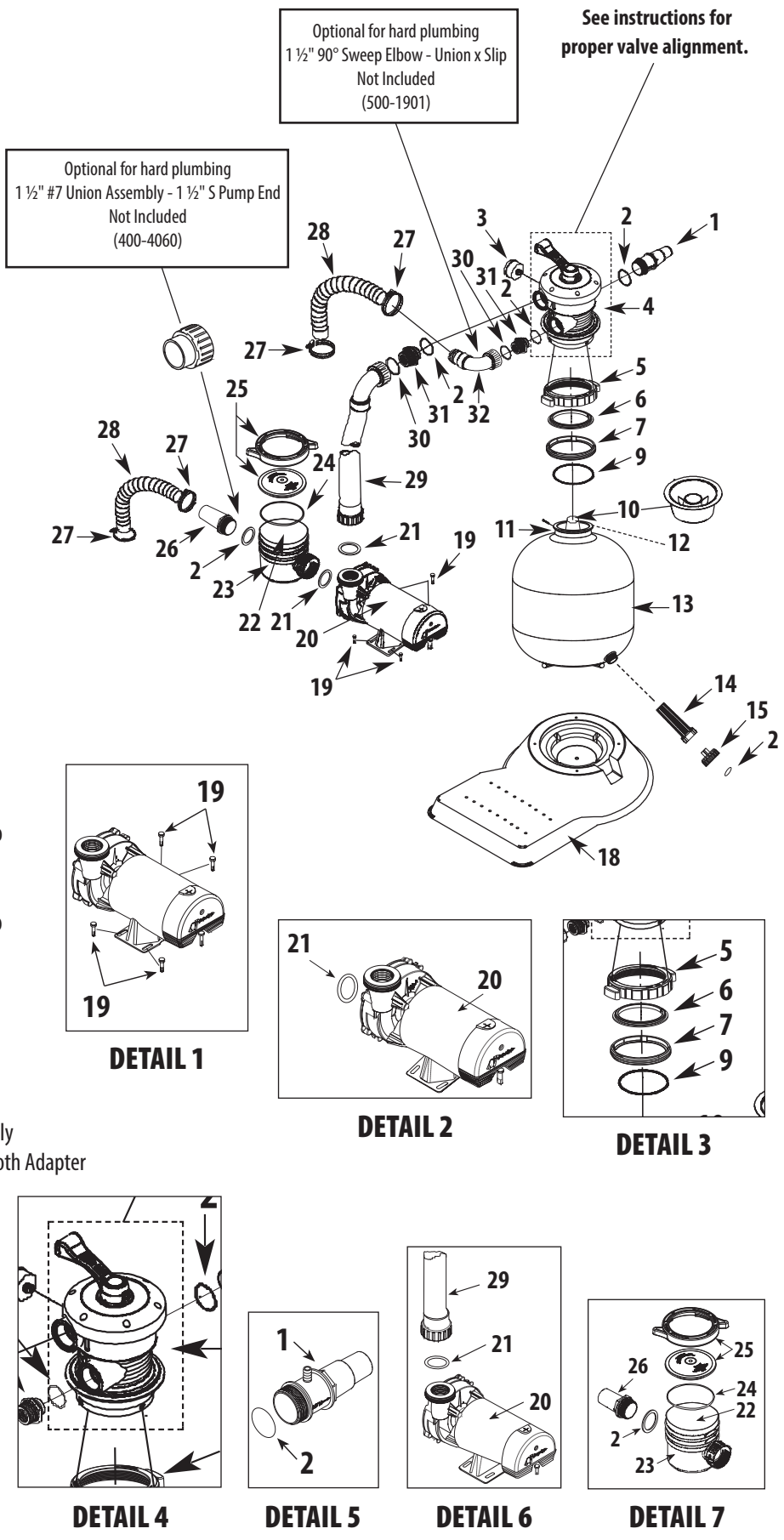

DETAIL 1

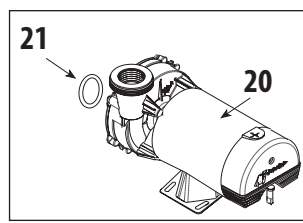

DETAIL 2

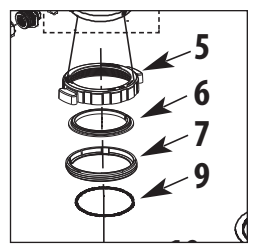

DETAIL 3

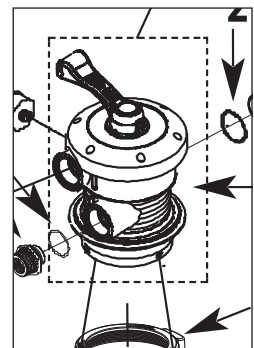

DETAIL 4

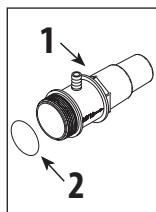

DETAIL 5

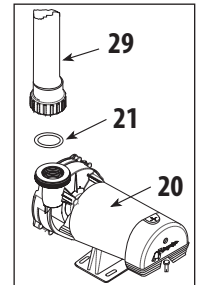

DETAIL 6

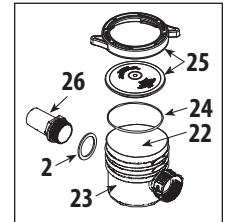

DETAIL 7

## TROUBLESHOOTING

<b>MOTOR DOES NOT START:</b>	Make sure motor is plugged in. Circuit breaker in OFF position. Thermal Overload in tripped position. Wiring installation incorrect. Incorrect line voltage. Defective wiring.	<b>EXCESSIVE PUMP NOISE:</b>	Worn bearings. Suction line clogged. Pump incorrectly mounted. Hose fitting partially closed. Slice valve partially closed. Clogged trap basket.
<b>THERMAL OVERLOAD TRIPS:</b>	Low voltage. Wiring installation incorrect. Dual voltage pumps mis-wired. Inadequate ventilation.	<b>INADEQUATE FILTERING:</b>	Sand level too low. Inadequately cleaned system. Excessive dirt load. Chemical imbalance. Inadequate system pressure.
<b>NO WATER FLOW:</b>	Obstruction of suction or return line. Clogged impeller. Suction system air leaks. Slice valve closed. Clogged hose fitting. Clogged basket. Dirty sand.		

**SAND FILL CHART:**  
**Model FS016 - 50 lbs.**  
**Model FS019 - 100 lbs.**  
**Model FS022 - 150 lbs.**  
**Model FS026 - 200 lbs.**

## CHLORINATOR & BROMINATOR USE WARNINGS

**READ AND FOLLOW ALL INSTRUCTIONS! SAVE THESE INSTRUCTIONS!**

**WARNING! To reduce the risk of injury and product damage:**



Feeders are designed to use only Chlorine (Trichloro-s-triazinetrione) or Bromine (Bromochloro -5, 5 Dimethylhydantoin) tablets, slow dissolving type. **UNDER NO CIRCUMSTANCES** MIX Trichlor OR Bromine with Calcium Hypochlorite, with other forms of concentrated chlorine, or with other chemicals **FIRE AND/OR EXPLOSION MAY RESULT.** **NEVER** use oils or grease to lubricate O-ring. Oil in contact with Trichlor OR Bromine may result in **FIRE.** Caution should be used when removing feeder cap. Do not inhale fumes.

If shock treatments or Algaecides containing chemicals other than sanitizer tablets in feeder must be used, then turn off feeder OR remove tablets until the shock or algae treatment is complete and all granules have dissolved. Failure to do so may result in granules mixing in feeder causing **FIRE AND/OR EXPLOSION.** The shock or algae treatment dissolved in water is safe with tablets.

**ALWAYS WEAR PROTECTION** for eyes, skin and clothing when working with chemicals. Do not smoke and avoid sparks and open flames. Turn off pump and control valve before opening chlorinator. Use of bulk chemicals may result in damage to pool. Chemicals will dissolve very quickly and may cause bleaching to liner due to over-chlorinating, possibly causing unsafe pool conditions.

Settings in excess of the recommended control setting levels for the chlorinator can result in excess chlorine being discharged in your pool. This can result in bleaching or discoloration of areas around the pool inlet or in some cases bleaching of the entire pool liner or paint (**CHECK CHEMICAL RESIDUALS REGULARLY**).

## WARRANTY

For product registration visit: [www.waterwayplastics.com](http://www.waterwayplastics.com).  
For Warranty questions or claims please contact point of purchase.



2200 East Sturgis Road, Oxnard CA 93030 • Phone 805.981.0262 • Fax 805.981.9403  
[www.waterwayplastics.com](http://www.waterwayplastics.com) • [waterway@waterwayplastics.com](mailto:waterway@waterwayplastics.com)

# ASSEMBLY INSTRUCTIONS FOR OVAL SAND FILTER SYSTEMS WITH ONE-PIECE BASE



1. Attach filter base to filter body by turning body upside down. Align drain on filter with clearance slot on base. Slip washer over bolt and thread bolt into filter body. **DO NOT OVER TIGHTEN.**



2. Turn filter over. Place next to pool between skimmer and return opening on pool. Place sand filter guide in filter over stand pipe. **Add approximately 6 inches of water before adding sand.** Add required #20 grade silica sand (see sand chart on back page). Remove sand fill guide and save.

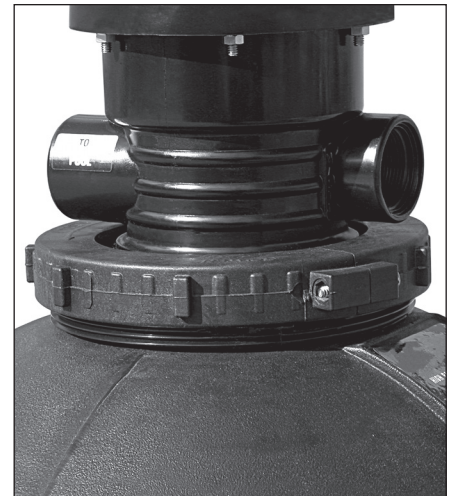

3. Place valve over threads on sand filter. Make sure dual outlets face pool and that top of filter is clear of any debris.



4. Tighten nut using wrench. Use one hand to turn wrench and the other hand to hold wrench in place.



5. Split-nut is fully installed when threads on body are not exposed. Retighten bolt on split-nut after installation to ensure valve is not loose.

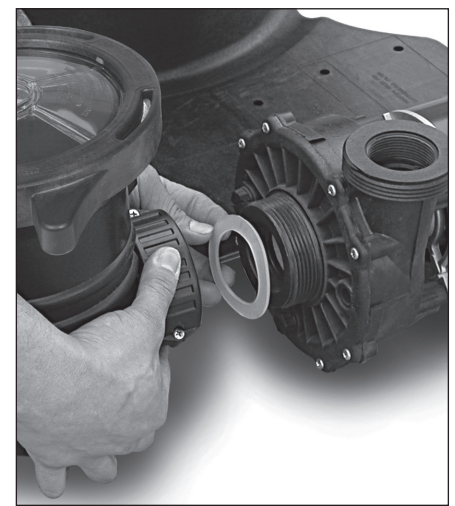

6. Install trap base to pump by removing gasket from inside trap. Remove clear trap lid, and place gasket in trap nut. Thread onto pump. **DO NOT OVER TIGHTEN.** Remember to replace trap lid.



7. Take O-ring and put over small side threads on 1 1/2" buttress x MPT fitting. Thread into pool outlet on valve. Repeat for pump outlet on valve.

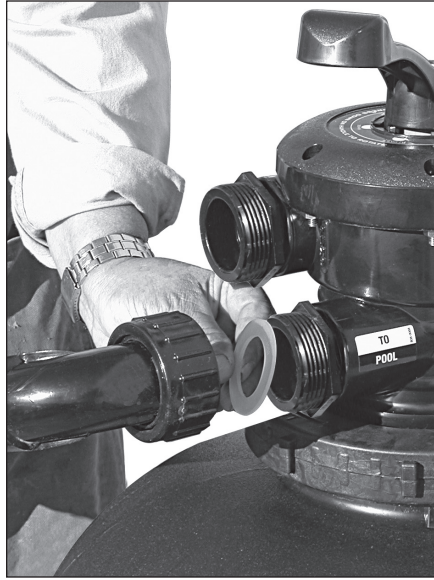

8. Put 1 1/2" gasket into return sweep assembly and install onto pool outlet port. **DO NOT OVER TIGHTEN.**



9. Take pump to filter hose assembly and put 1 1/2" gasket into nut on smaller end with sweep 90°. Thread onto pump outlet port. **DO NOT OVER TIGHTEN.**

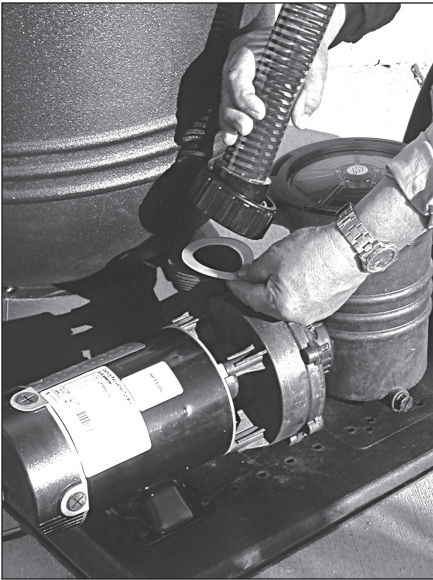

10. Put 2" gasket into nut on hose labeled "TO VALVE PUMP PORT." **DO NOT OVER TIGHTEN.**



11. Put O-ring over threads on 1 1/2" smooth straight hose adapter and thread into front of pump basket.

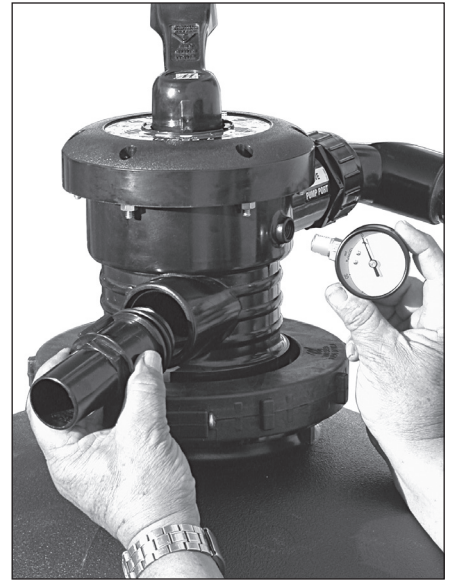

12. Apply Teflon tape to pressure gauge threads (4 wraps is ideal) and thread into valve. Install waste adapter by pushing O-ring over threads of adapter and threading into waste port.

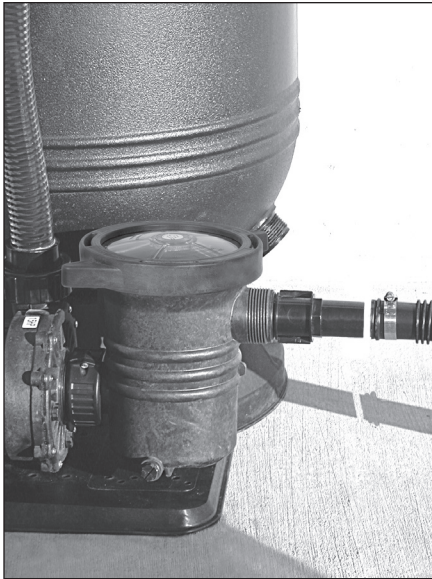

13. Install 6 ft. corrugated hoses by loosening hose clamps and sliding over hose ends. Install hose onto pump basket hose fitting by pushing on and tightening clamp. Install other end of hose onto skimmer and tighten clamp.

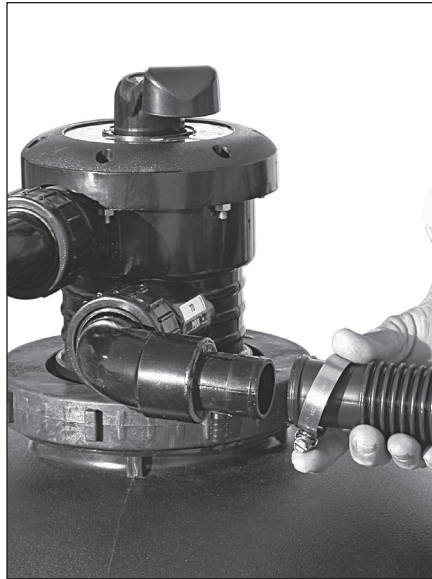

14. Install hose onto smooth hose adapter in valve by loosening hose clamp and sliding over adapter end. Install other end onto return fitting of pool and tighten clamps.



15. To remove drain screen, remove drain screen cap/wrench and insert the wrench end into drain screen opening and unscrew. When reinserting drain screen **DO NOT OVER TIGHTEN** (be sure O-ring is inside of drain cap). Screw on drain screen cap/wrench. **DO NOT OVER TIGHTEN.**

**NOTE:** After starting system, if there is leaking at connections including the valve, shut off system and retighten slightly. Then restart the system. Repeat if necessary. If leaking does not stop, it may be necessary to remove fittings or valve to check for missing O-rings and/or gaskets. **When reapplying Teflon tape, do not reuse old tape. Remove old tape before adding new tape.**

#### REQUIRED AMOUNT OF #20 GRADE SILICA SAND

16" Filter	100 lbs.
19" Filter	150 lbs.
22" Filter	250 lbs.
26" Filter	300 lbs.

#### WARRANTY

For product registration visit: [www.waterwayplastics.com](http://www.waterwayplastics.com).  
For Warranty questions or claims please contact point of purchase.



2200 East Sturgis Road, Oxnard CA 93030 • Phone 805.981.0262 • Fax 805.981.9403  
[www.waterwayplastics.com](http://www.waterwayplastics.com) • [waterway@waterwayplastics.com](mailto:waterway@waterwayplastics.com)

# 1 1/2" MULTI-PORT 7-FUNCTION SAND FILTER VALVE

## VALVE MULTI-PORT 1 1/2" À 7 FONCTIONS POUR FILTRE À SABLE

### MULTI-VALVULA DE 7 FUNCIONES DE 1 1/2" PARA FILTRO DE ARENA

#### VALVE FUNCTIONS • FONCTIONS DE LA VALVE • FUNCIONES DE VALVULA

Freeze Protection: All ports are self-draining to prevent freeze damage.  
**WARNING:** Pump should not be running while valve is in this position.

Tous les ports sont fermés. La pompe peut être entretenue dans ce mode.  
**AVERTISSEMENT:** La pompe ne devrait pas fonctionner lorsque la valve est dans cette position.

Protección de congelación: Todos los puertos se desaguan para prevenir daño de congelación.  
**ADVERTENCIA:** La bomba no debe funcionar mientras que la válvula está en esta posición.

All ports are closed. Pump can be serviced in this mode.  
**WARNING:** Pump should not be running while valve is in this position.

Tous les ports sont fermés. La pompe peut être entretenue dans ce mode.  
**AVERTISSEMENT:** La pompe ne devrait pas fonctionner lorsque la valve est dans cette position.

Todos los puertos son cerrados. Puede darle mantenimiento a la bomba en esta estación.  
**ADVERTENCIA:** La bomba no debe funcionar mientras que la válvula está en esta posición.

**Bypass to Waste:** Vacuum dirty water from pool. Water flows through multi-port valves, bypassing filter to waste port.

**Vidanger :** L'eau passe par la valve multi-port, ensuite est dévié pour être vidangée.

**Puente al agua sucia de Basura:** Aspire agua sucia de la piscina. El agua atraviesa las válvulas del multi-puerto, pasando el filtro a la puerta de basura.

**Filtration Cycle:** Water flows through sand bed and discharges to filter outlet. This is the normal operating position.

**Cycle de Filtration :** L'eau traverse le lit de sable pour ensuite décharger dans la piscine. C'est la position normale de fonctionnement.

**Ciclo de Filtración:** El agua atraviesa la arena y descarga en la puerta del filtro. Ésta es la posición de funcionamiento normal.

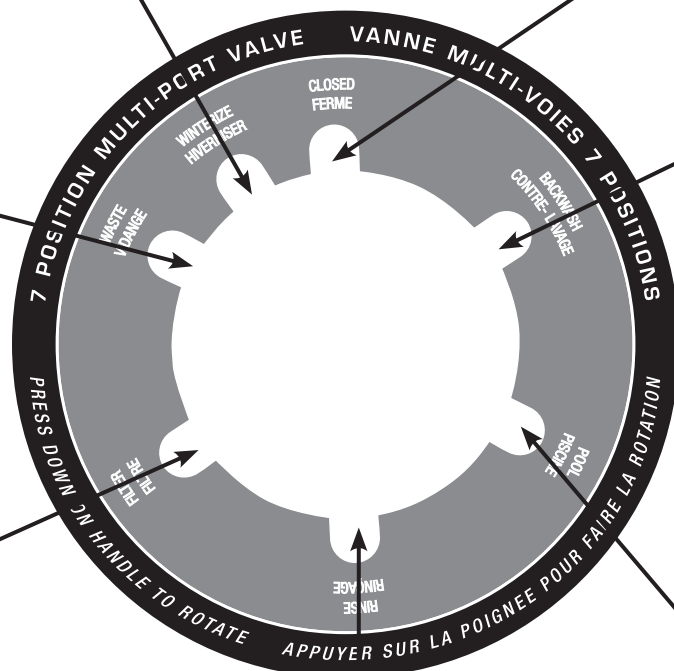

**Reverses water flow of filter and discharges out waste port:** Water flows up from tank laterals, stirs debris on sand bed surface, then flushes debris to waste port.

**Les inverses arrosent l'écoulement du filtre et les décharges hors de la perte port :** L'eau coule du fond vers la surface du réservoir, remue les débris sur la surface, rince et vidange ceux-ci.

**Reversa la corriente del agua del filtro y descarga en la puerta de basura:** Agua fluye para arriba de laterales del tanque, revuelven desechos en superficie en arena, después salen los desechos a la puerta de basura.

Recirculates pool water while by passing filter. Water flows into filter inlet and discharges through filter outlet.

Recycle l'eau de la piscine sans passer par le filtre.

Recircula el agua de la piscina mientras que pasa el filtro. El agua fluye en la entrada del filtro y descarga en la salida del filtro.

Rinses excess sand that is trapped in the filter laterals, septum and diffuser. Water flows through filter inlet and discharges through waste port.

Rince le sable excessif qui est emprisonné dans les parties latérales, le septum et le diffuseur de filtre. L'eau traverse l'admission et les décharges de filtre par le port de rebut.

Enjuaga en exceso la arena que esta atrapada en los laterales y el difusor del filtro. El agua atraviesa en la entrada del filtro y descarga a través de la puerta de basura.



2200 East Sturgis Road, Oxnard CA 93030 • Phone 805.981.0262 • Fax 805.981.9403

www.waterwayplastics.com • waterway@waterwayplastics.com



# REPLACING A MULTI-PORT VALVE ON A SAND FILTER

## FOR WATERWAY OVAL FILTERS

- 1) Remove connections and unthread the old multi-port body from the filter body.
- 2) Using a Phillips screwdriver - remove the screw from the threaded sleeve on the filter body
- 3) Replace the threaded sleeve with:

New threaded sleeve R7 version on all size models manufactured before 2024

New threaded sleeve R7 version on all 16" and 19" models manufactured before 2025

New threaded sleeve R5 version on all 22" and 26" models manufactured 2024 to present

New threaded sleeve R5 version on all 16" and 19" models manufactured in 2025

- 4) Install the new multi-port valve

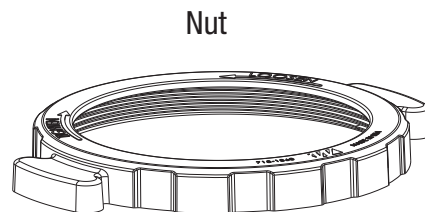
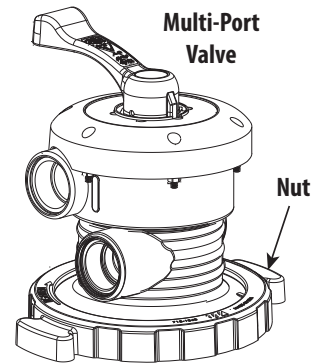

### WARRANTY

For product registration visit: [www.waterwayplastics.com](http://www.waterwayplastics.com).  
For Warranty questions or claims please contact point of purchase.