

CLEAR WATER™ **WATER** D.E.



D.E. SYSTEM OWNER'S MANUAL

CLEARWATER II D.E. FILTER SYSTEM OWNER'S MANUAL

Our ClearWater II D.E. Filter System is shipped from Waterway complete with everything you need right in the box. Assemble filter system only after above-ground pool is installed. Fill pool with water. Do not raise water level above pool return line.

The pool equipment should be located between pool skimmer and return line. The filtration system should not be closer than 2 ft. and not further than 5 ft. from the pool. The ClearWater II D.E. Filter System needs to be on a completely flat surface (e.g. patio block, cement slab, etc.). The pump will require a 110 volt/20 amp service.



WARNING: A GFCI is required. Follow national and local building and safety codes.

Before opening shipping carton, make sure box is in the upright position. Inside the carton, you will find:

1. One base
2. One pump (packaged in separate box)
3. One filter
4. Two lengths of 6 ft. hose
5. One bag with fittings

INSTALLATION INSTRUCTIONS



WARNING! READ ALL INSTRUCTIONS AND WARNING LABELS BEFORE OPERATING FILTER!

1. Place filter and base on a level, secure surface. Place the pump on the base to the left of the filter. The pump should now be facing the filter marked "Inlet". There is no need to disassemble filter or pump assemblies.
2. Open pump trap lid and remove 2" gasket. Place 2" gasket into union nut. Hand tighten union nut to suction side of pump (Detail 5).
3. Secure pump to the base using the pin & anchor assemblies (Detail 4).
4. Open fittings bag and remove coupling assembly (Detail 2). Assemble 2" gasket, coupling, coupling O-Ring, and 2" union nut, and thread into inlet side of filter.
5. Thread 2" union nut to pump discharge (Detail 3). Thread hose adapter with O-Ring, to pump trap suction side (Detail 1).
6. From the fittings package, remove 1½" hose adapter and O-ring (Detail 2, #21 & 22). Thread into the outlet side of the filter tank.
7. Remove 4 hose clamps from the fittings bag. Select one of the hose lengths and slip one clamp over the end of hose adapter. Place the end of the hose on to the hose adapter (pump suction) and the other end to the hose adapter end of the pool skimmer. Repeat steps with filter outlet to pool return.
8. Remove the Lid Handle, #1, from the fittings bag and attach it to the top of the Lid Assembly, #12, as shown (Detail 6). Secure ClearWater Filter to ClearWater Filter Base using #24a Phillips Head Screws (2) (Detail 6a & 6aa). Fill pool until water level is halfway up length of skimmer throat.
9. Open air release knob. Plug in and turn on pump. Air will pass out of the filter through the air release knob. Once water discharges from knob, close it.

NOTE: To remove Lid Assembly, take off Filter Nut, #3, insert Filter Wrench, #20a, in notch between Filter Body, #20 and Lid Assembly, #12, twist and separate as shown in Detail 6a.

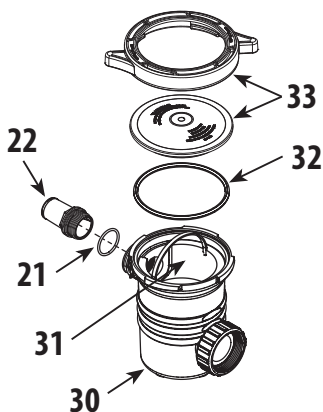

DETAIL 1

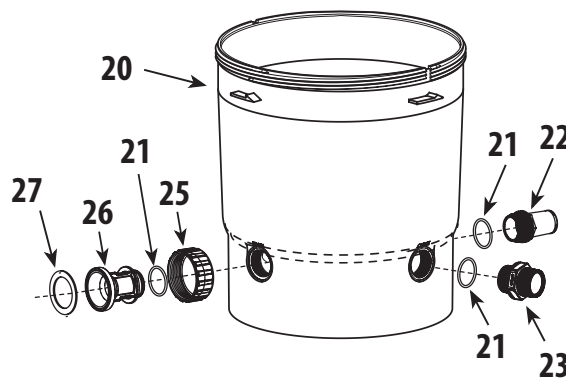

DETAIL 2

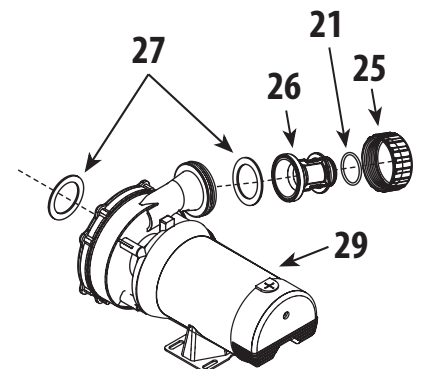

DETAIL 3

CLEARWATER II D.E. FILTER SYSTEM REPLACEMENT PARTS

Item	Part No.	Description
1	519-7601	Lid Handle
2	819-9002	#12 x 3/4" S/S Phillips Head Screw
3	718-7251	Filter Locknut Assembly
4	602-0200	Air Relief Plug
5	805-0207	O-Ring - Air Relief
6	830-4000SS	Pressure Gauge
7	519-7451	Handle Assembly (2)
8	805-0224	O-Ring - Air Relief
9	519-7430	Gauge - Fitting Adapter
10	805-0117SD	O-Ring - Adapter
11	805-0460	Lid O-Ring
12	519-7411	Lid Assembly (Small)
	519-7401	Lid Assembly (Large)
13	519-7441	Wing-Nut
14	500-7310	Screen/Sock Assembly
15	718-7210	Tie Nut - D.E.
16	419-7241	Plug - 2" x 1 1/2" MPT
17	519-7269	Locator - Top Grids - D.E.
18	550-7210	D.E. Grids - 12 sq. ft. (7)
	550-7220	D.E. Grids - 18 sq. ft. (7)
19	550-7100	Base Assembly - 12 sq. ft.
	550-7120	Base Assembly - 18 sq. ft.
20	515-7251	Filter Body Bottom
20a	519-7470	Filter Wrench (see Detail 6a)
21	805-0224	O-Ring (4)
22	417-6241	1 1/2" MPT x 1 1/2" Male Smooth Hose Adapter (2)
23	500-5300	Drain Assembly
24	672-7401	ClearWater II Base
24a	819-0044	#10 x 1" S/S Phillips Head Screw (2)
25	415-5001	2" Union Nut
26	419-7241	Coupling
27	711-4010	2" Union Gasket (2)
28	429-7221	Snap Pin (4)
29	PH1100	1 HP - 1-Speed Hi-Flo II Pump
	PH1150	1 1/2 HP - 1-Speed Hi-Flo II Pump
	PH1200	2 HP - 1-Speed Hi-Flo II Pump
	PH2100	1 HP - 2-Speed Hi-Flo II Pump
	PH2150	1 1/2 HP - 2-Speed Hi-Flo II Pump
	PH2200	2 HP - 2-Speed Hi-Flo II Pump
30	310-6500	6" Trap - 1 1/2" Buttress x 2" Flange
31	319-3230	6" Basket Assembly
32	805-0436	O-Ring
33	319-4100	2-Piece 6" Pump Trap Lid Assembly

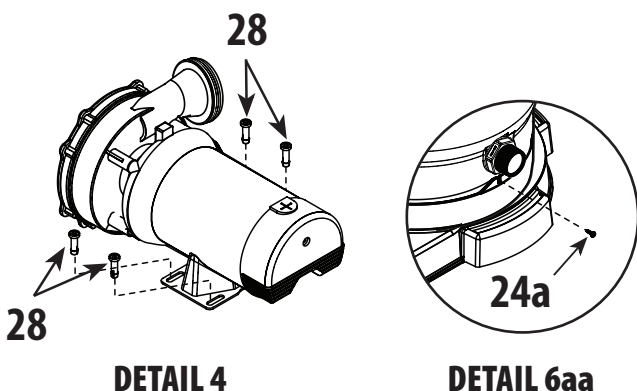
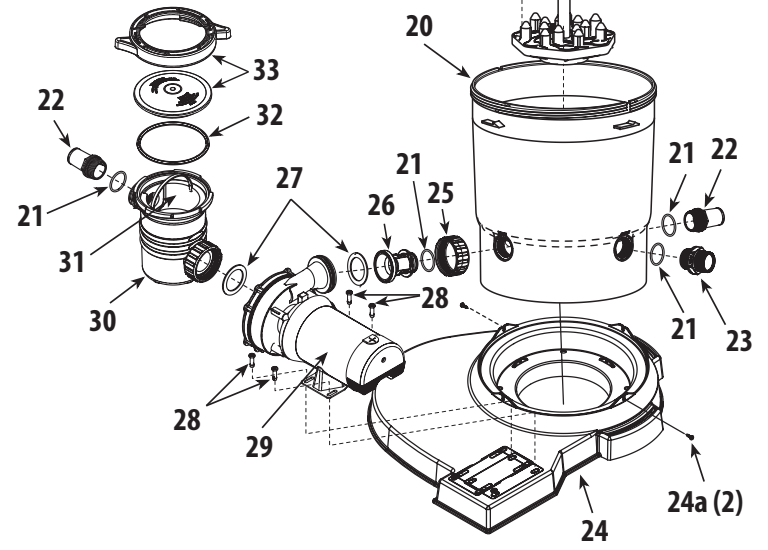
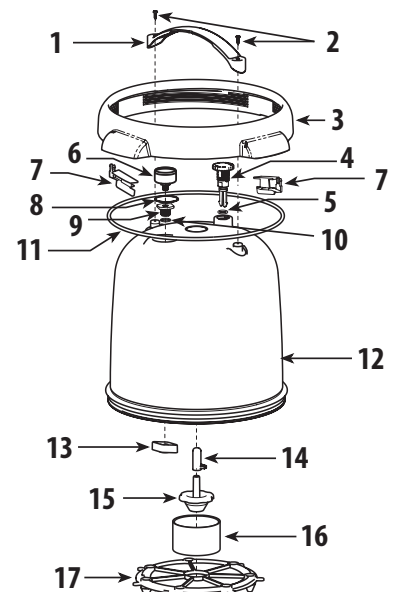
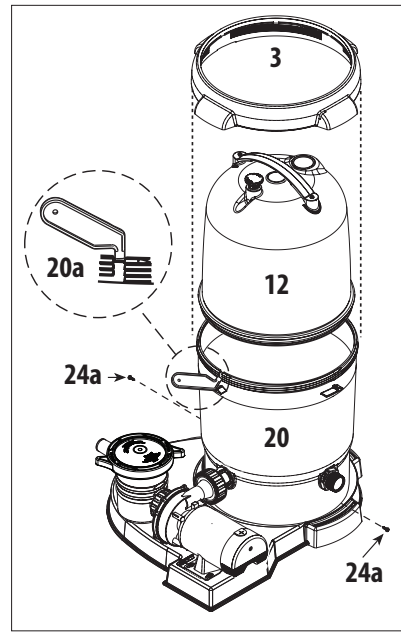
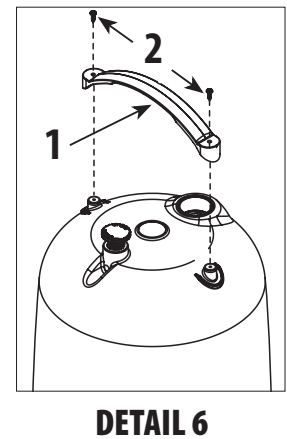
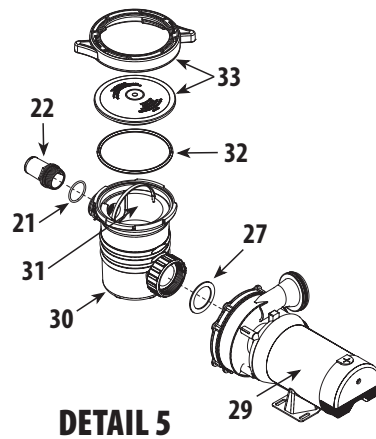

CLEANING INSTRUCTIONS

If the pressure gauge on your filter reads 5 PSI or higher than the original starting pressure, the filter needs to be cleaned. The ClearWater II D.E. Filter System features the exclusive 1-2-3 Safety Locking System to ensure safe and simple filter maintenance.

1. Turn off pump. **WARNING: Never attempt to clean filter while pump is running. This is a pressurized vessel. It could cause severe injury or harm to your person.** Plug skimmer and pool return lines or drain pool water level to below pool return line.
2. Slowly open the air release knob on top of filter until the pressure gauge reads "0". Open drain cap at bottom of filter and allow water to flow.

3. Press the yellow safety latch on the underside of the locking nut and turn the nut counterclockwise to remove the lid. Rinse the D.E. element with a garden hose. There is no need to remove the element from the filter.
4. Reassemble lid and follow start-up procedures from original instructions.

My Original Starting Pressure is _____ PSI (Pounds per Square Inch). I should clean the filter at _____ PSI.

WARRANTY

**For product registration visit: www.waterwayplastics.com.
For Warranty questions or claims please contact point of purchase.**



2200 East Sturgis Road, Oxnard CA 93030 • Phone 805.981.0262 • Fax 805.981.9403
www.waterwayplastics.com • waterway@waterwayplastics.com

D.E. FILTER CLEANING INSTRUCTIONS



WARNING: NEVER ATTEMPT TO CLEAN FILTER WHILE PUMP IS RUNNING. This is a pressurized vessel. It could cause severe injury or harm to your person.

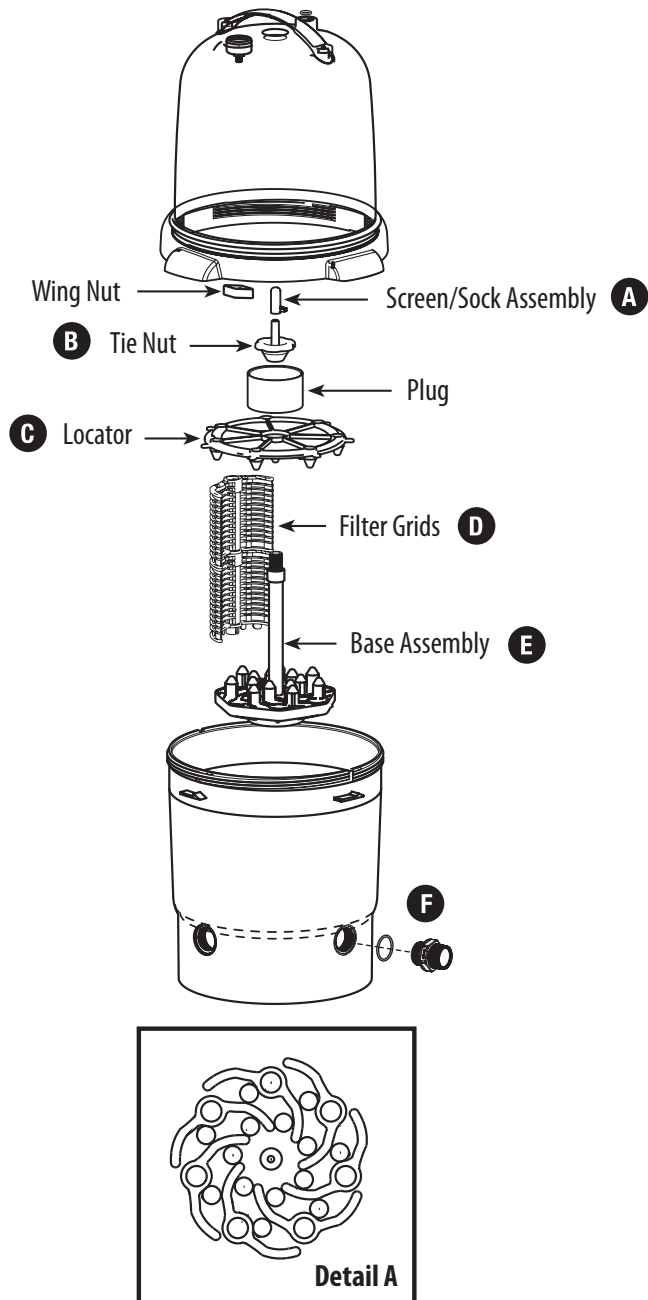

CLEANING INSTRUCTIONS

1. Remove the filter lid.
2. Remove filter drain cap (F).
3. Remove internal filter screen (A). Clean debris from inside of screen area.
4. Unthread tie nut (B). Lift and remove grid locator (C).
5. Gently remove all 7 filter grids (D). Rinse grids off using a low pressure water source.
6. Place clean filter grids (D) on Base Assembly (E). See Detail A for grid alignment on the collector (Top View).
7. Place grid locator (C), tie nut (B) and filter screen (A) in place.

START UP

1. Make sure filter lid is secured to filter bottom.
2. Replace filter drain cap. Open slice valves (if applicable). Open air relief valve.
3. Turn pump on. **Do not stand over or near the filter. Stay at least 10 feet clear from the filter.** When a steady stream of water discharges, shut off the air relief valve.
4. You are now ready to add D.E. to your filter. Diatomaceous Earth (D.E.) is the filter media that will coat the filter grids.
5. **Minimum D.E. needed: Add at least 1 lb. of D.E. for each 10 sq. ft. of filter area: (suggested by Waterway)**

For FD12 models: 12 sq. ft. / 44 GPM = **1.2 lbs.**
For FD18 models: 18 sq. ft. / 67 GPM = **1.8 lbs.**
6. Mix the D.E. into a slurry in a pail and add it through the pool skimmer while the filter is running.
7. Your pool is now ready for your enjoyment!

WARRANTY

For product registration visit: www.waterwayplastics.com.
For Warranty questions or claims please contact point of purchase.



2200 East Sturgis Road, Oxnard CA 93030 • Phone 805.981.0262 • Fax 805.981.9403
www.waterwayplastics.com • waterway@waterwayplastics.com

INSTALLATION INSTRUCTIONS FOR ATTACHING CLEARWATER II FILTER LID HANDLE AND REMOVAL OF LID ASSEMBLY

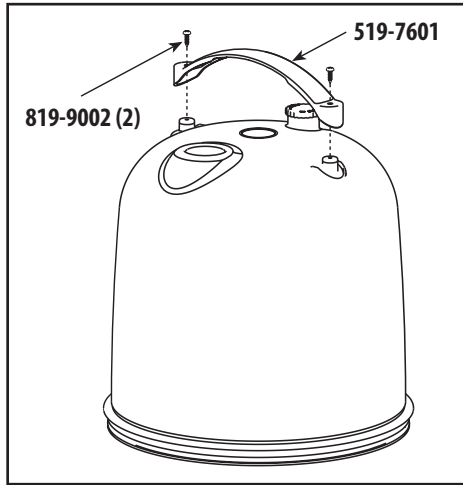

Using a Phillips-head screwdriver, screw the two (2) provided Phillips-head screws through the handle assembly and into the filter lid, as shown. Make snug; DO NOT overtighten.

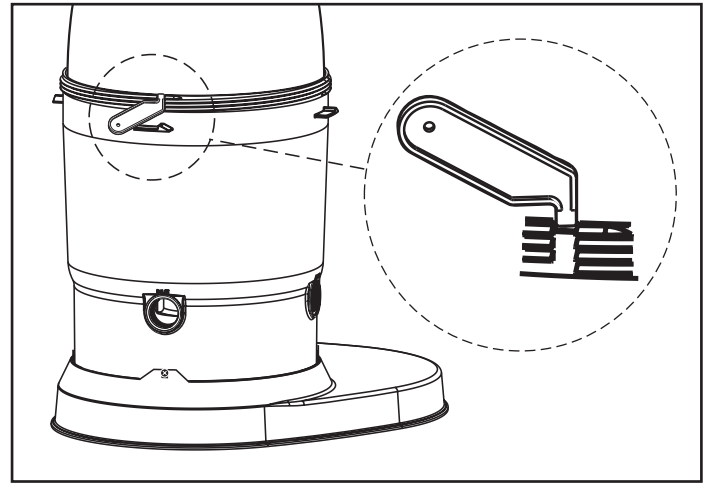

TO REMOVE LID ASSEMBLY:

Remove lock-nut assembly. Insert wrench in notch between filter body and lid assembly as shown. Twist wrench to separate.

INSTALLATION INSTRUCTIONS FOR ATTACHING CLEARWATER II FILTER BODY TO THE CLEARWATER II FILTER BASE

1. Align the drain port of the filter body to the base as shown.
2. Use one of the two self-threading screws provided. Screw it into the filter body as shown.
3. Using the other self-threading screw, screw it into the filter body on the opposite side.
4. Continue the installation of the filter according to the filter instructions.



WARRANTY

For product registration visit: www.waterwayplastics.com.
For Warranty questions or claims please contact point of purchase.



2200 East Sturgis Road, Oxnard CA 93030 • Phone 805.981.0262 • Fax 805.981.9403
www.waterwayplastics.com • waterway@waterwayplastics.com

Instructions d'installation pour la pose de la poignée du couvercle du filtre ClearWater II et l'enlèvement de l'assemblage du couvercle

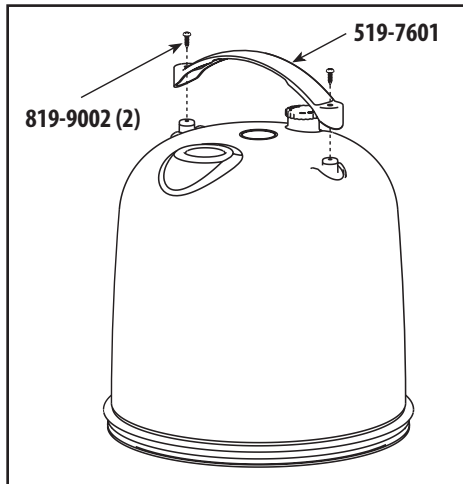

Avec un tournevis Phillips, visser les deux vis Phillips fournies à travers la poignée dans le couvercle du filtre tel que montré (ne pas trop serrer).

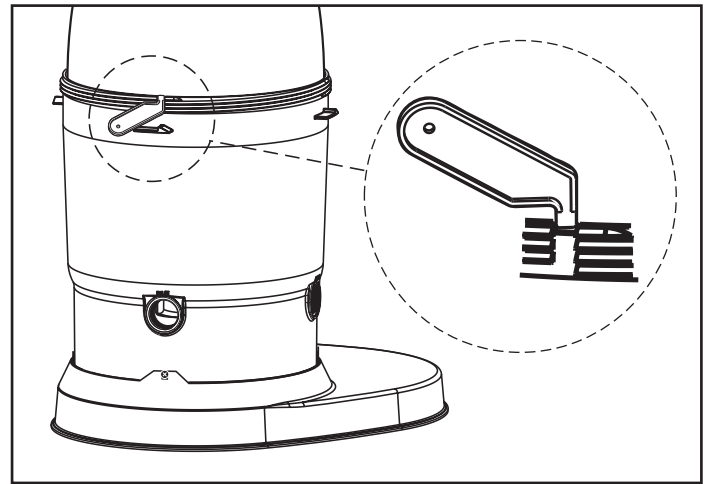

Pour enlever le couvercle :

Enlever l'écrou autobloquant, insérer la clé dans la rainure entre le boîtier et le couvercle du filtre tel que montré et faites pivoter la clé pour les séparer.

Instructions d'installation pour la pose du boîtier du filtre Clearwater II à la base du filtre Clearwater II

1. Aligner la sortie du drain du boîtier du filtre avec la base tel que montré.
2. Utiliser une des deux vis à filetage automatique fournies et la visser dans le boîtier tel que montré.
3. Utiliser l'autre vis à filetage automatique et la visser dans le boîtier, du côté opposé.
4. Continuer l'installation du filtre selon les instructions du filtre.



GARANTIE

Pour l'enregistrement du produit, visitez : www.waterwayplastics.com.

Pour des questions de garantie ou réclamations, veuillez communiquer avec point de vente.



2200 East Sturgis Road, Oxnard CA 93030 • Phone 805.981.0262 • Fax 805.981.9403

www.waterwayplastics.com • waterway@waterwayplastics.com