

56-FRAME EXECUTIVE EURO PUMP SAFETY INSTRUCTIONS

For Model Numbers: PF-10-1N22X • PF-20-1N22X • PF-20-2N22X • PF-25-2N22X • PF-30-1N22X

SAVE THESE IMPORTANT ORIGINAL SAFETY INSTRUCTIONS

ALL ELECTRICAL INSTALLATIONS SHOULD BE PERFORMED BY QUALIFIED ELECTRICIANS

2-SPEED MODELS: DO NOT wire both speeds to run simultaneously. If supply cord is damaged, replace only with original replacement equipment available from authorized dealer.

The pump is to be supplied through a residual current device (RCD) with a rated residual operating current not exceeding 30mA.

Potential risk of fire, electrical shock, or injury to persons if misused.

DO NOT install within an outer enclosure or beneath the skirt of the spa unless so marked.

WARNING: To reduce the risk of injury, do not permit children to use this product unless they are closely supervised at all times.

- Persons with reduced physical, sensory or mental capabilities or lack of experience & knowledge, should not use this product unless they are supervised or have been given the proper instructions.
- Children should not play with this product.

CAUTION: This pump is for use with permanently installed pools and may also be used with hot tubs and spas if so marked. Do not use with storable pools. A permanently installed pool is constructed in or on the ground or in a building such that it cannot be readily disassembled for storage. A storable pool is constructed so that it may be readily disassembled for storage and reassembled to its original integrity.

PUMP CONNECTIONS INSTALLATION INSTRUCTIONS

LOCATION: Place pump on level surface. Pump must be installed below water surface. Shut off valves should be installed on both the inlet and outlet of the pump for future maintenance. Installation area should be clear of any direct water and have adequate floor drainage. Pump should be protected from excessive moisture.

The inlet and outlet have waterway male union threads. Use waterway tailpiece assemblies for best connection. These unions allow the pump to be removed for service without disturbing the plumbing. **HAND TIGHT UNIONS ONLY!**

Do not use pipe dope. Use only Teflon tape or other sealing compounds approved for use with plastic. Some pipe dopes not approved for use with plastic will cause stress cracking of plastic parts. New installations often require a plumbing inspection. This inspection is usually conducted using city water pressure. A pressure regulator should be used when performing this test and should not exceed 40 PSI during the pressure test. The filter and pump are under pressure. Insure that all air is removed during the pressure test. **FAILURE TO FOLLOW THESE INSTRUCTIONS EXPLICITLY CAN RESULT IN PERSONAL INJURY.**

MOTOR WIRING

1. Before working on any electrical connections be sure that the power is turned off.
2. All wiring must conform to local, state and/or national codes.
3. All wiring must conform to wiring diagram on the motor nameplate or on the back of the terminal cover.
4. Applied voltage must correspond to rated voltage as indicated on marking plate.
5. **FOR SAFETY CLASS 1 EQUIPMENT:** It is mandatory to connect the pump to the protective conductor (grounding connector) of earth-grounded main power supply.
FOR EQUIPOTENTIAL BONDING: It is also possible in addition to use the external terminal on the body to realize an equipotential bonding with other earthed metallic parts.
6. **DO NOT ground to a gas supply line.**
7. Ground motor prior to connecting electrical power.
8. For disconnection from the supply, a circuit breaker having a contact separation of at least 3mm in all poles must be incorporated in the fixed wiring according to the wiring rules. Cord and plug provided with pump is intended to be used with mating spa pack connector.
9. Improper grounding can cause serious injury and damage to the motor, voiding the warranty.
10. If the supply cord is damaged, it must be replaced by a special cord or assembly available from the manufacturer or its service agent.

STARTING AND PRIMING PUMP

Before turning the power on, be sure that:

1. There is an adequate amount of water in the system.
2. All valves are open to allow water circulation.
3. All connectors and fittings are properly aligned and secured.
4. All electrical connections are proper,

CAUTION: DO NOT RUN THE PUMP WITHOUT WATER. If the pump fails to prime within 30 seconds, turn it off and check for an air lock, clogged plumbing or closed valves. If the pump will not start or prime, see the troubleshooting section in the manual.

MAINTENANCE INSTRUCTIONS

Keep the motor clean. Ensure that the louvered openings are free from debris and obstructions. Over a period of time, the shaft seals may become damaged or worn and must be replaced.

WINTERIZATION - To prevent damage during freezing conditions, disconnect all electrical power. Drain thoroughly and clean out any debris. Protect pump and motor from elements by covering or, if possible, store in a dry, well ventilate room.



Read the instruction manual carefully.

WARRANTY

For product registration visit: www.waterwayplastics.com.

For Warranty questions or claims please contact point of purchase.

MODEL	AMP	VOLTAGE	HMAX
PF-10-1N22X	5.0	230	13.4
PF-20-1N22X	8.7	230	16.2
PF-20-2N22X	9.3 / 1.8	230	16.2 / 5.0
PF-25-2N22X	10.3 / 1.8	230	16.9 / 5.7
PF-30-1N22X	12.6	230	19.0

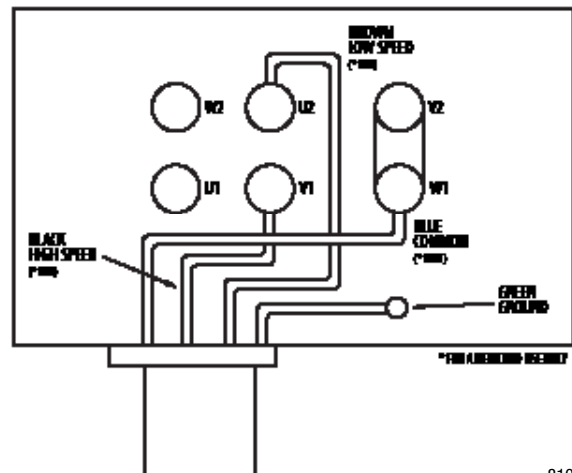

ENSURE WIRING CIRCUIT AGREES WITH DIAGRAM AND LEADS ARE SECURELY TIGHT.

TROUBLESHOOTING

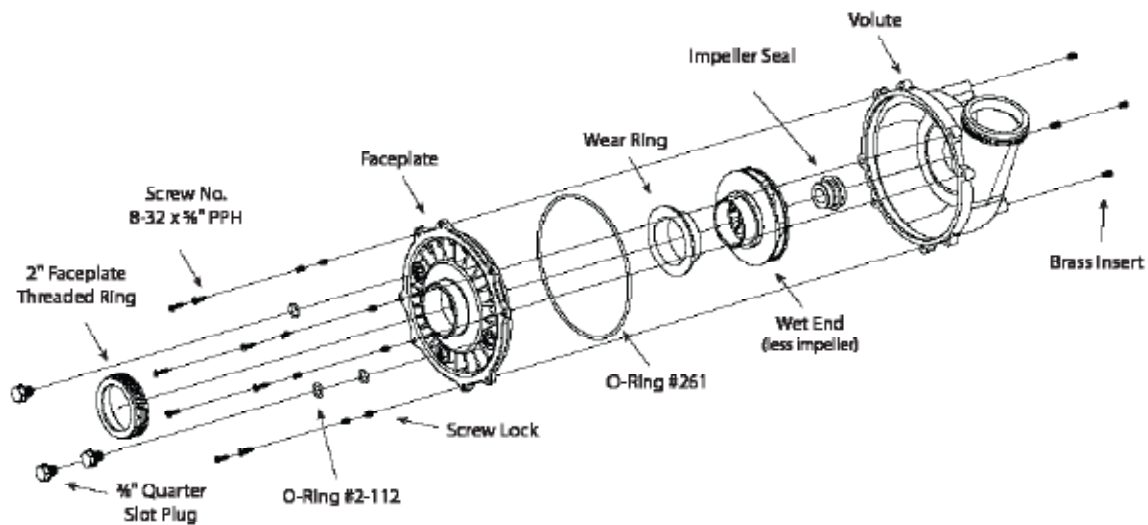
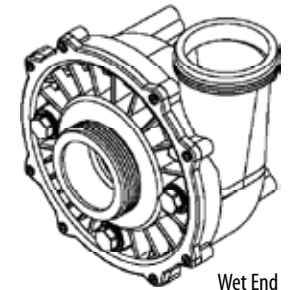
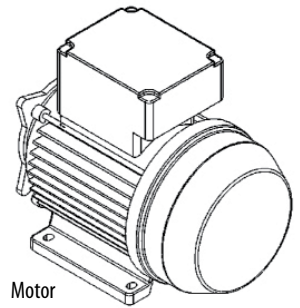
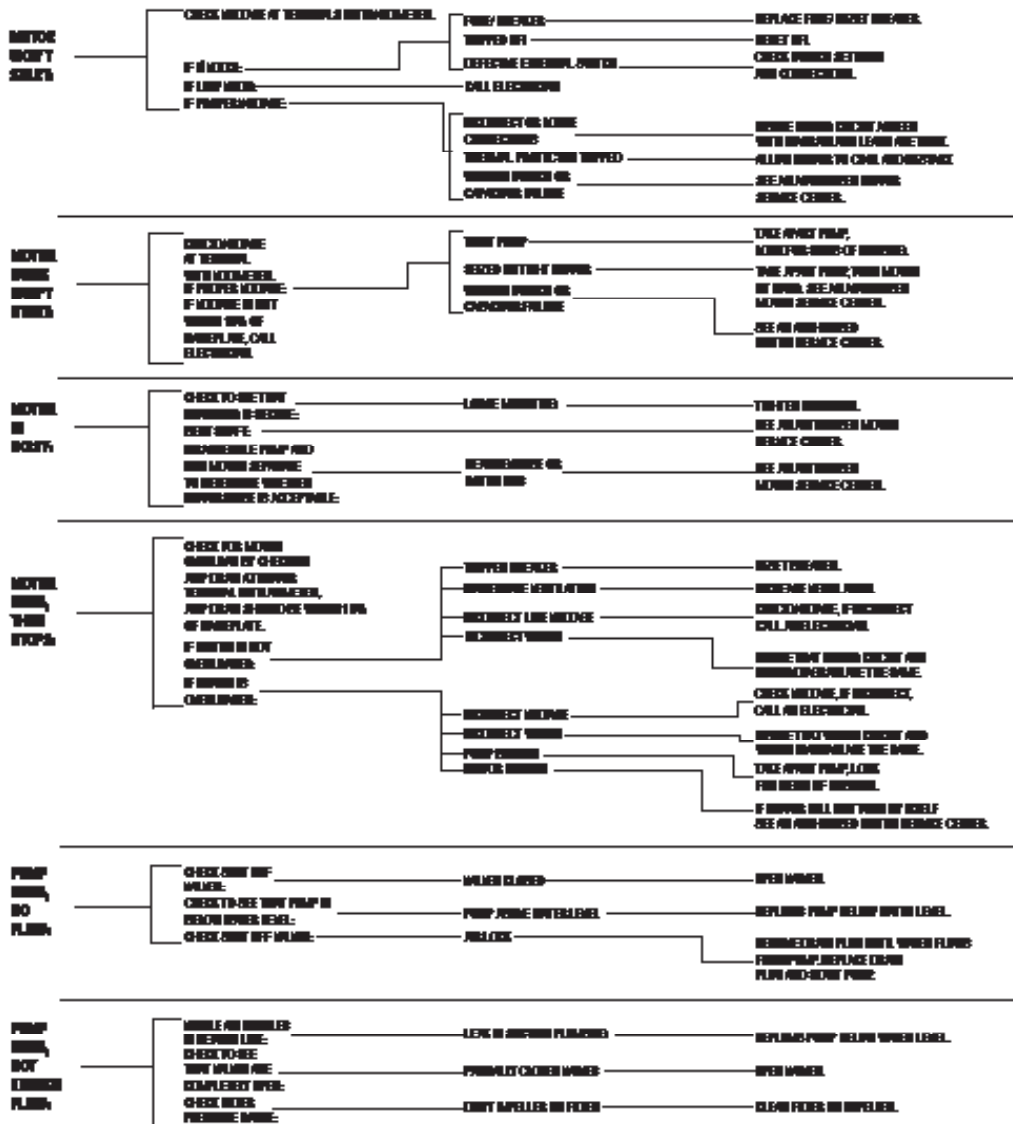

2200 East Sturgis Road, Oxnard CA 93030 • Phone 805.981.0262 • Fax 805.981.9403
www.waterwayplastics.com • waterway@waterwayplastics.com