

CLEARWATER IN-LINE CHLORINATOR INSTALLATION INSTRUCTIONS

Automatic In-Line Chlorinator • 2 1/2" Spigot and 1 1/2" FPT

SAVE THESE INSTRUCTIONS:

Read all instructions prior to assembly.

NOTE: NOT FOR USE IN COPPER PLUMBING.

- **POSITION THE CHLORINATOR:** The In-Line Chlorinator must be permanently installed in the pool return line. To prevent damage from high concentrations of chlorine, locate in return line between pool and any other components of the circulation system, including heater, filter and pump (see Figure 1).

- **TURN PUMP AND FILTER SYSTEM OFF**

- **SHUT VALVES**

The Chlorinator must be installed in a vertical, upright position (lid up). The Chlorinator comes equipped with fittings required for installation. Cut pipe at required location for your situation. To prevent damage to the pool heater, install a corrosion-resistant swing check valve (*not supplied*) on the return side, in between the pool heater and chlorinator (see Figure 1).

Make sure arrow of check valve is pointing away from equipment and in direction of water flow to the pool. Glue in chlorinator and check valve using approved PVC solvent cement. Chlorinator will accept 2" PVC. For 1 1/2" PVC, use 2" x 1 1/2" reducer (P/N 421-4070).

To allow for adding chlorine and servicing when installing below pool's water level, gate or ball valves must be installed on both sides of chlorinator.

NOTE: When heaters are installed, a FIREMAN'S SWITCH or equivalent must be installed to prevent heat damage to check valves and other equipment.

Chlorine levels should be checked periodically to monitor the amount of chlorine in the water. Refer to **OPERATING INSTRUCTIONS** to properly set chlorine level.

CLEANING INSTRUCTIONS

To ensure continuous peak performance, periodic maintenance may need to be performed.

- **NOTE:** Turn off pump and filter system and shut valves before servicing.

- **TURN PUMP AND FILTER SYSTEM OFF**

- **SHUT VALVES**

- Loosen and remove lid. Lift screen from bottom of chlorinator (see Figure 2). Check valve, located at bottom inside body assembly, may also be removed by using a 1" socket. Clean parts with a brush, hose or other high pressure device. Use protective eye wear. Use Teflon tape when replacing check valve. Calcium deposits indicate a high pool/spa pH and should be corrected by adding acid in very small amounts until pH reads between 7.2 and 7.6 (7.4 is ideal). If condition persists consult a pool/spa serviceman in your area who is familiar with any local water condition problems and can correct them for you.

FIGURE 1

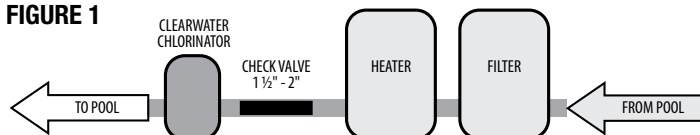

Designed,
Engineered &
Manufactured
in the USA.

Waterway™

2200 East Sturgis Road, Oxnard CA 93030 • Phone 805.981.0262 • Fax 805.981.9403

OPERATING INSTRUCTIONS



Read all instructions prior to operation:
Always follow manufacturer's directions.

SAFETY: Care must be used. Use gloves and eye protection. DO NOT SMOKE. Do not inhale fumes.

TO INSTALL TABLETS:

1. Shut off and close valve on inlet side of chlorinator.
2. Slowly rotate lid by turning counterclockwise.
3. If refilling with chemicals – allow fumes to escape. See product label for specific warnings and information.
4. Place chlorine tablets inside of canister. Be certain that the first tablet is seated flat on top of screen. **DO NOT stack tablets above fill line, or top of canister.**
5. Before screwing on lid, make sure that O-ring is clean and seated securely in lid (see Figure 2).
6. Hand tighten lid. **DO NOT over-tighten!**

TO OPERATE:

- **OPEN INLET VALVE**
- **TURN PUMP AND FILTER SYSTEM ON**
- **CHECK FOR LEAKS**

WARNING:
**DO NOT MIX CHLORINE
AND BROMINE TOGETHER.
FIRE AND/OR EXPLOSION
MAY RESULT!**

SETTING KNOB CONTROL:

1. Some trial and error will be required to establish the proper setting for your use and filter cycle time, which will determine the proper position for the control knob.
2. Start by turning knob to mid point on indicator.
3. Allow one to two days for the chlorine level to stabilize.
4. Check chlorine level with a test kit:
 - If level is below 1 ppm – try a higher setting.
 - If level is above 2 ppm – try a lower setting.

Repeat these steps until proper setting is found.

NOTE: The ClearWater Chlorinator is not designed for shock treatment of pools. See your dealer or distributor for information concerning shock treatments.

LEVELS: pH: 7.2 – 7.6 • Alkalinity: 80 – 100ppm

IMPORTANT: It will not be possible to maintain a proper level if above levels are not maintained or if proper shock and stabilizers are not used.

NOTE: If your pool has any of the following equipment, install a corrosion-resistant swing check valve:

- Brass or bronze gate, rotary or backwash valves.
- The preceding valves constructed of PVC or other plastic material with metallic shafts.
- Filters, heaters, heat exchangers or other items with metallic tanks, shafts, coils or tubes.

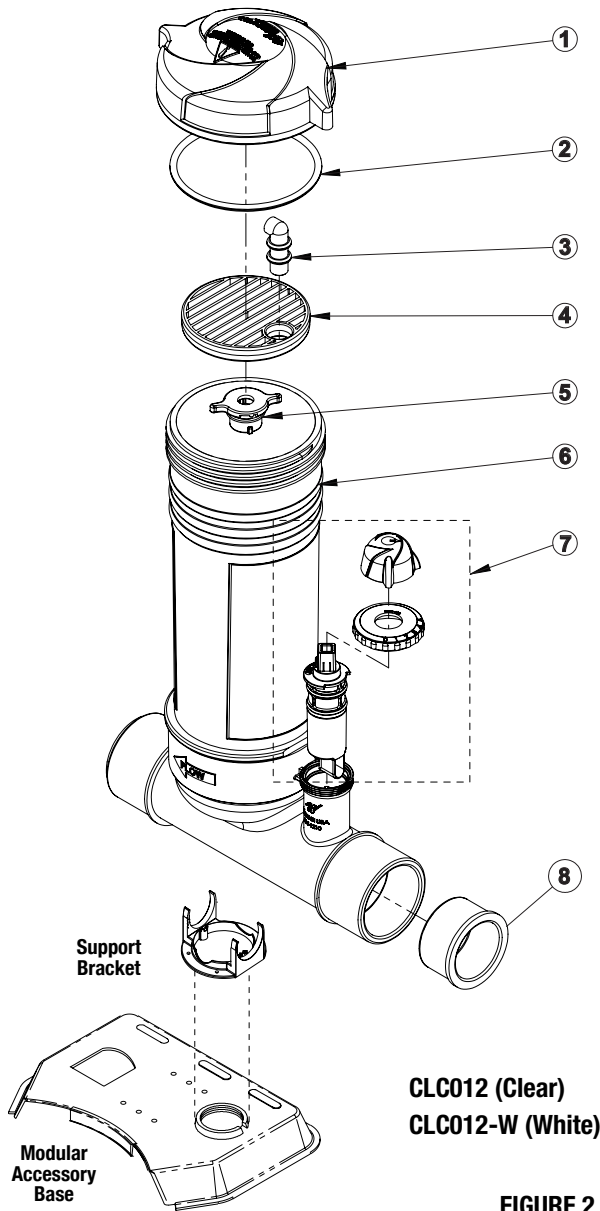
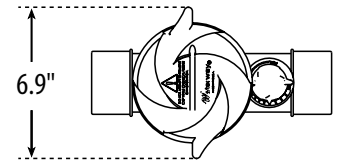
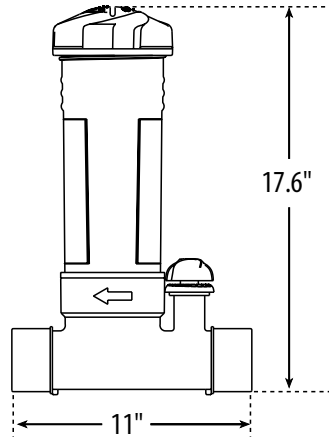

FIGURE 2



IN-LINE CHLORINATOR REPLACEMENT PARTS

Item	Part No.	Description
1	519-1167	Lid
2	805-0348V	Lid O-Ring
3	411-1170	90° Elbow
4	519-1400	Filter Screen
5	600-1290	Check Valve Assembly
6	--	Body Assembly
7	600-1287	Stem Assembly
8	421-4070	Reducer
	550-6700	In-Line Chlorinator Bracket ClearWater Modular Accessory Base

WARNING • READ AND FOLLOW ALL INSTRUCTIONS • SAVE THESE INSTRUCTIONS



WARNING! To reduce the risk of injury and product damage:

ALWAYS be sure system is OFF before performing any maintenance. This feeder is designed to use only Chlorine (Trichloro-s-triazinetriene) or Bromine (Bromochloro-5, 5 Dimethyl hydantoin) tablets, slow dissolving type. UNDER NO CIRCUMSTANCES MIX Trichlor OR Bromine with Calcium Hypochlorite, with other forms of concentrated chlorine or with other chemicals. FIRE AND/OR EXPLOSION MAY RESULT. NEVER use oils or grease to lubricate O-ring. Oil in contact with Trichlor OR Bromine may result in FIRE. Caution should be used when removing feeder cap. Do not inhale fumes. No shock treatments or Algaecides containing chemicals other than sanitizer tablets are to be used in feeder. The shock or algae treatment dissolved in water is safe with tablets. ALWAYS WEAR PROTECTION for eyes, skin and clothing when working with chemicals. Do not smoke and avoid sparks and open flames. Turn off pump and control valve before opening chlorinator. Use of bulk chemicals may result in damage to pool. Chemicals will dissolve very quickly and may cause bleaching to liner due to over-chlorinating, possibly causing unsafe pool conditions. Settings in excess of the recommended control setting levels for the chlorinator can result in excess chlorine being discharged in your pool. This can result in bleaching or discoloration of areas around the pool inlet or in some cases bleaching of the entire pool liner or paint. Check chemical residuals regularly.

WARRANTY

For product registration visit: www.waterwayplastics.com.
For Warranty questions or claims please contact point of purchase.